

## ADDENDUM 2

DATE: 5/02/2018  
PROJECT: UCT Switchgear Replacement  
RFP NO: 744-R1807  
OWNER: The University of Texas Health Science Center at Houston  
TO: Prospective Proposers

This Addendum forms part of and modifies Proposal Documents dated, 1/30/2018, with amendments and additions noted below.

### Questions & Answers and Revised Drawings and Specifications

Q1. Dwg. E200, Note 10, indicates concrete encasement of the Fire Pump Feeder between the new Enclosed Breaker and the existing controller. Is this encasement required within the room the equipment is residing?

**SSA/MEP Response:**

**-Concrete encase feeders for fire pumps are required.**

**Pinnacle/Structural Response:**

**-Shah Smith to comment on encasement. Pinnacle understanding is that once the conduit is through the occupied space, encasement is no longer required.**

Q2. Are the expansion joints shown on any of the contract documents?

**SSA/MEP Response:**

**-Refer to specifications section 26 05 33.**

**Pinnacle/Structural Response:**

**-This is referring to expansion joints at the conduits, correct?**

Q3. Dwg. E602 shows a partial grounding diagram, where do you find the quantity of electric rooms or xfmr's that require connection? Also are there contract documents showing where the genset's are located?

**SSA/MEP Response:**

**-The grounding risers are existing. This contractor shall intercept existing risers on level one east and west electrical rooms.**

**-The 3 generators are located on the roof of the garage level 6 of the building.**

Q4. Does the freight elevator go to the basement and if so what are the dimensions and weight capacity?

**SSA/MEP Response:**

- Yes, the freight elevator goes to the basement.
- Door Height – 7’
- Door Width – 4’6”
- Inside Car Height – 10’
- Inside Car Width – 7’3”
- Inside Car Depth – 4’ 5”
- Capacity 3,500 pounds

Q5. The specifications concerning conduit type and locations installed was contradictory. Can EMT be used for the feeder conduits in the garage or will rigid conduit be required?

**SSA/MEP Response:**

- Rigid conduit will be required.

Q6. A-111 and S301 indicate a concrete encasement around the vertical conduits. Neither show rebar reinforcement. Is steel rebar reinforcing required? Due to site logistics is CMU block encasement an acceptable alternative to encase these conduits

**Pinnacle/Structural Response:**

- Pinnacle understanding is that CMU is not an acceptable alternative. Shah Smith to confirm. See revised detail on S301 on Revision 01 drawings dated 3/2/18.

Q7. S201 Level 3 floor slab and S202 Level 4 floor slab indicate a 5” Wide trench to be cut for conduit risers. Confirm these riser conduits do not need to be encased with concrete or CMU.

**Pinnacle/Structural Response:**

- Shah Smith to confirm. Pinnacle understanding is that these conduits do not need to be encased.

Q8. Please provide a detail for the (10) new traffic bollards shown on A-111. Confirm mounting details (IE: bolt to top of deck, or under deck with a welded plate, etc.)

**PhiloWilke/Architectural Response:**

- Bollards are to be surface mounted, product manufacturer provided for the bollards.

**Pinnacle/Structural Response:**

- Philo Wilke to confirm bollard type/manufacturer. Attachments to existing concrete slab shall be per manufacturer.

Q9. No concrete mix design or PSI rating is provided in contract drawings, also no specific concrete sealer is called out, specifications do not include a concrete division. please provide direction via drawings/specification

**Pinnacle/Structural Response:**

-Concrete mix requirements are provided in Section III of the General Notes on sheet S101 of the contract drawings.

Q10. No finish schedule for new CMU walls, doors and frames was provided. Please provide a finish schedule and appropriate spec sections.

PhiloWilke/Architectural Response:

-Exterior CMU walls to be painted white on the exterior only and remain unpainted inside the electrical room. Doors and frames to match the adjacent finishes of the existing room on the same level. Spec sections provided in Addendum 01.

Q11. A new type S1 CMU wall is to be constructed on L2 facing the street and should receive plaster/stucco per the partition schedule and subsequent detail G-102:13. Please provide direction as to the type of finish, plaster or stucco, and relevant specification.

PhiloWilke/Architectural Response:

-Wall type S1 will not have stucco/plaster, wall is to be painted white.

Q12. No hardware schedule/specs and door/frame spec were provided. Please provide door, frame and hardware spec/schedule.

PhiloWilke/Architectural Response:

-Specs to be provided in Addendum 01.

Q13. Per 26 05 16: 3.2: B splicing is not permitted, however 26 05 16: 3.2:H and 26 05 16: 3.2: L mention the use of split bolt connectors and approved splices respectively. May engineered mechanical splices be used when necessary?

SSA/MEP Response:

-This contractor shall use long barrel inline compression lugs for all splices.

Q14. Please confirm that this project is to follow the most recent Davis-Bacon minimum wage requirements for Harris County, Texas. Minimum wage rates found at <http://www.gpo.gov/davisbacon>

SSA/MEP Response:

-This is confirmed.

Q15. Please confirm that a full time superintendent is required for the duration of the project.

SSA/MEP Response:

-A full-time superintendent is required.

Q16. Specification 26 05 33 2.1 G. 3. allows EMT to be used in exposed areas above 8'. All of the existing conduit installed in the garage is EMT and it is below 8'. Are we to use rigid steel conduit for all conduit runs in the garage since it is below 8'?

**SSA/MEP Response:**

All exposed conduit shall be rigid galvanized steel.

Q.17. Specification 26 05 33 3.2 O. 1. a. indicates the maximum size EMT that can be used is 1-1/2". Specification 26 05 33 2.1 G. indicates the use of EMT up to 4". Please clarify the maximum size for use of EMT, 4" or 1-1/2"?

**SSA/MEP Response:**

-All exposed conduit shall be rigid galvanized steel.

Q18. Specification 26 05 33 3.2 O. 1. f. indicates the DB conduit where encased in concrete. Please confirm we can use DB conduit for the concrete incased feeders from the Center Point Vault to 2000A service entrance circuit breakers and from the Center Point Vault to the existing Fire Pump Controllers since they are concrete encased.

**SSA/MEP Response:**

-DB conduit in concrete is acceptable.

Q19. Please clarify the intent of specification 26 14 00. Are we to provide Coordination Study and Arc Flash Study for new equipment only? Or are the studies to include downstream existing electrical switchgear?

**SSA/MEP Response:**

-Coordination study and arc flash for new equipment only.

Q20. On drawing E002A item 3 under UT UCT BUILDING/SEQUENCE OF WORK calls for a \$300K allowance for CPE work. Please confirm GC is to carry this allowance.

**SSA/MEP Response:**

-This contractor shall carry a 50k allowance for CPE work. The new T&C will state that.

Q21. On drawing E002A item 9 under UT UCT BUILDING/SEQUENCE OF WORK calls for the contractor to be responsible for the fuel usage for the Data Center and Building Generators during shutdowns. Please provide the number of generator(s), size of generator(s) and load of generator(s) so that the fuel consumption can be calculated.

**SSA/MEP Response:**

-The existing generator is 600KW/750KVA and it is natural gas.

Q22. On drawing E002A item b. under 2. ELECTRICAL SHUTDOWN FOR PANEL E indicates Temporary Power if required. Please confirm an allowance defined by UTHSC will be in place for any required temporary power needed for any shutdown work? Please confirm the electrical sub-contractor should not carry this allowance. All shutdown sequences indicate temporary power may be needed. Please provide a Temporary Power Allowance amount to be carried.

**SSA/MEP Response:**

-This contractor shall carry an allowance of 5k for any required shutdown.

Q23. On drawing A-101 (Level 4.5 Garage Electrical Room) shows the guard rail being removed in two locations. Do the 4 concrete pedestals need to be removed? Or just the steel rub rail?

**PhiloWilke/Architectural Response:**

-Just the Rail. The pedestals will need to be removed on the plan North side of Room 2E01 on Level 2. Drawings clarifying demolition will be provided in Addendum 01.

Q24. On drawing E040 keyed note 2 calls for all AHU's to be connected to the central control panel located in the engineering office and to coordinate with Division 23. Please clarify what the scope is for Division 26?

**SSA/MEP Response:**

-Control wiring

Q25. Drawing E010 indicates an existing Chiller with no keyed note. Please confirm we are to remove this feeder? Renovation one-line E030 does not indicate a backfeed for this chiller. Please confirm none is required.

**SSA/MEP Response:**

-There is no existing feeder in place.

Q26. Please provide feeder size from MSBB to 5DPH on drawing E030.

**SSA/MEP Response:**

-New 4-600KCMIL, 1#2/0G, 3 1/2" C

Q27. Drawing E602 indicates a West Ground Riser and an East Ground Riser from level 1 to the Penthouse and the 26th Floor respectively. Please clarify if we are to ground existing transformers in all of the electrical rooms that the ground risers serve? This seems to be indicated as typical on the east ground riser. If we are to ground ALL existing transformers, please provide a count and size of transformers.

**SSA/MEP Response:**

-The grounding risers are existing and all existing transformers are grounded.

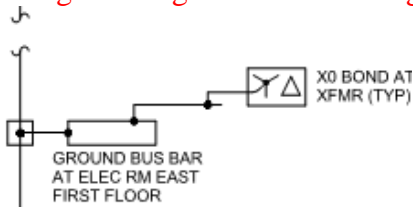

Q28. Drawing E602 indicates ground connections to existing generators but the location of the existing generators is not shown on the floor plans. Please provide floor plan locations.

**SSA/MEP Response:**

-Existing generators are on the garage roof, level 6 of the building.

Q29. Drawing E602 indicates ground connections to the existing ground loop. Please confirm it is acceptable to connect to the ground loop where it is accessible at its building entrance and not at the inaccessible ground rods at the ground loop.

**SSA/MEP Response:**

-It is acceptable.

Q30. Please clarify what the #350 aluminum ground is from and for per keyed note 11 on drawing E030?

**SSA/MEP Response:**

-It is in place in existing electrical room of level 24. It needs to be tied to the new ground bus.

Q31. Please clarify keyed note 13 on drawing E200. Is it the same item as keyed note 1 on drawing E010? Demolition of this feeder is not indicated on E010. Should we include in our scope demolition of a 1200A feeder from the lower level to the 22nd floor?

**SSA/MEP Response:**

-Keyed note 13 shall read level 20. This contractor shall remove existing feeder as shown on the one-line.

Q32. Please confirm that the IT Riser indicated on detail 4/E050 and floor plans is to remain and not be removed?

**SSA/MEP Response:**

-IT riser shall remain.

Q33. Please confirm the Fire Smoke Dampers in the Center Point Vault on drawing E200 are new and to be fed from panel EA per General Note C.

**SSA/MEP Response:**

-That is correct.

Q34. Sheet S202 shows a new CMU electrical room on the 4th floor and sheet S203 shows a new electrical room on the fifth floor. Is this the same electrical room or are there two electrical rooms this size?

**Pinnacle/Structural Response:**

-It is the same room. The level upon which the new room is actually in between the 4<sup>th</sup> and 5<sup>th</sup> floors (due to the ramp configuration).

Q35. How tall are the CMU walls for all new electrical rooms? Can a section through the garage be provided to show the CMU wall heights?

PhiloWilke/Architectural Response:

-Walls are to go to deck, GC to verify the height between the parking garage floor level surface and the bottom of deck.

Pinnacle/Structural Response:

-CMU should go to the underside of the concrete structure above, and contour around beams, joists, etc. See details 3 and 6 on S301. Heights should be field verified.

Q36. Detail 2/S301 shows #5 rebar and grout fill at 48" on center vertically. Usually the first four courses of CMU parking garage walls near traffic areas have rebar and grout fill in every cell as bumper protection from getting hit by vehicles. Please advise if the architect wants this additional rebar and grout fill.

Pinnacle/Structural Response:

-CMU wall is currently designed to withstand code-required impact load overall. Bollards will be provided to discourage traffic close to the walls. The recommendation is good, but since these walls are on existing beams and joists, the weight of the wall needs to be kept to a minimum to avoid over-loading the existing structure.

Q37. What are the logistical plans to get materials to the work areas and are there going to be any time restrictions for getting materials to the work areas?

SSA/MEP Response:

-We do not dictate means and methods for contractors. The contractor who is awarded this contract will coordinate the logistical plan and all deliveries with ODR. No lane closures or large deliveries that would impede access to the garage or facility can be taken during normal business hours from 7 am to 6 pm on weekdays.

Q38. Detail 1/A101 indicates to relocate a fire strobe and associated conduit. It does not show where to relocate nor does it show on the electrical drawings. Please advise.

SSA/MEP Response:

-To be coordinated with UTHHealth.

Q39. Please provide bollard details and attachment details that are referenced on A-111.

PhiloWilke/Architectural Response:

-Bollards are to be surface mounted, product manufacturer provided for the bollards.

Pinnacle/Structural Response:

-See response to Q8 above.

Q40. Note 17/E030 says Contractor shall bid the replacement of existing MCC-1 as Alternate No. 01 however the bid form for Alternate #1 states this is a deductive alternate to keep the existing MCC1 (implying we should include replacement in our base bid). Same for Alternate No. 2 and note 18/E030. Please clarify which should be included in base bid versus Alternate.

**SSA/MEP Response:**

- Base scope will be to replace MCC1. Alternate #1 will be a deductive alternate to leave the existing MCC in place.
- Base scope will be to replace Panel PHH. Alternate #2 will be a deductive alternate to leave Panel PPH in place.

Q41. Are there any expansion joints in the parking garage or building that need to be accounted for? Can these be indicated on a drawing.

**SSA/MEP Response:**

- This information needs to be field verified.

Q42. Are there any heat tracing/freeze protection required of plumbing/sprinkler piping in the garage?

**SSA/MEP Response:**

- Sprinkler piping is understood to be existing dry system, and as such no heat trace is required. Existing domestic cold water lines being utilized as tie in point to new hose bibb are understood to be insulated without heat trace in place. New domestic cold water line to new hose bibb shall be insulated and hose bibb will be freeze-proof. Owner to verify if heat trace will be desired for new line.

Q43. Dwg E002A

- a. Ref' UT UCT Building sequence of work, item #3: Section references back up power, CPE work, etc. Please detail exactly what the \$300k allowance is to cover.

**SSA/MEP Response:**

- The T&C will cover the scope. This contractor shall carry an allowance of 50k.

- b. Sheet E002A references concrete encased feeders for fire pumps and utility feeders. Can these feeders be encased in other types of equal fire rated and UL approved systems?

**SSA/MEP Response:**

- Concrete encased

- c. Ref' UT UCT Building sequence of work, item #9: Please confirm if data center generator is gas.

**SSA/MEP Response:**

- All UCT generators are natural gas.



- d. Please confirm if ALL building generators are gas. If not, please provide sizes and type of fuel.

SSA/MEP Response:

-All UCT generators are natural gas.

- e. Electrical Shutdowns for fire pumps

- i. Item C states to run the feeders from the enclosed circuit breakers however one line drawing on E030 shows the feeders coming directly from the CPE transformer. Please confirm which is correct.

SSA/MEP Response:

-New fire pump feeders form CPE vault.

Q44. Does vendor dispose of all old gear, pipe, etc. off site?

SSA/MEP Response:

-Yes.

Q45. Is UT keeping any old equipment such as buss duct, etc.?

SSA/MEP Response:

-No

Q46. Spec Section: 23 34 13 FANS -3.1 INSTALLATION

Detail section 3 (Titled: "Section 8") on mechanical page: M-101 shows the elevation view for ventilation fan SF-M-1. It is scheduled to be a QEID In-Line Greenheck fan with 10HP Internal motor moving Outside Air; 15,000 CFM @ 0.5" SP.

When checked against Greenheck's Catalogs this Scheduled fan weighs at least 1,100 lbs. Per the detail the fan is to be supported from floor below, if elevations are true, then a vertical support span of over 9ft A.F.F is required. The specifications do not address installation of a floor mounted suspended fan.

- a. How will the basement ventilation fan (Outside Air) SF-M-1 be supported from below?

SSA/MEP Response:

-Contractor to provide unistrut or angle iron stand bolted to the floor and adequately braced for this weight and application. The fan would be supported from the mounting brackets/housed restrained isolators on the fan.

- b. What are acceptable materials and construction techniques to furnish and install such support?

SSA/MEP Response:

-2-1/2 X 2-1/2 X 1/4 angle iron or 12 Ga. unistrut

Attached is the pertinent section view for reference, with scaled dimensions for reference only.  
Can we possibly get a clarification on this? (see Exhibit A)

# FAN SUPPORT R.F.I. 2/19/18 - EXHIBIT A

The University of Texas  
Health Science Center at  
Houston

## UCT SWITCHGEAR REPLACEMENT

### MECHANICAL ROOM BASEMENT

SSA Project Number	1095-027-01
Date	01-18-2018
Designed By	RGG
Checked By	JG
Drawing No.	

# M-101

Scale As indicated

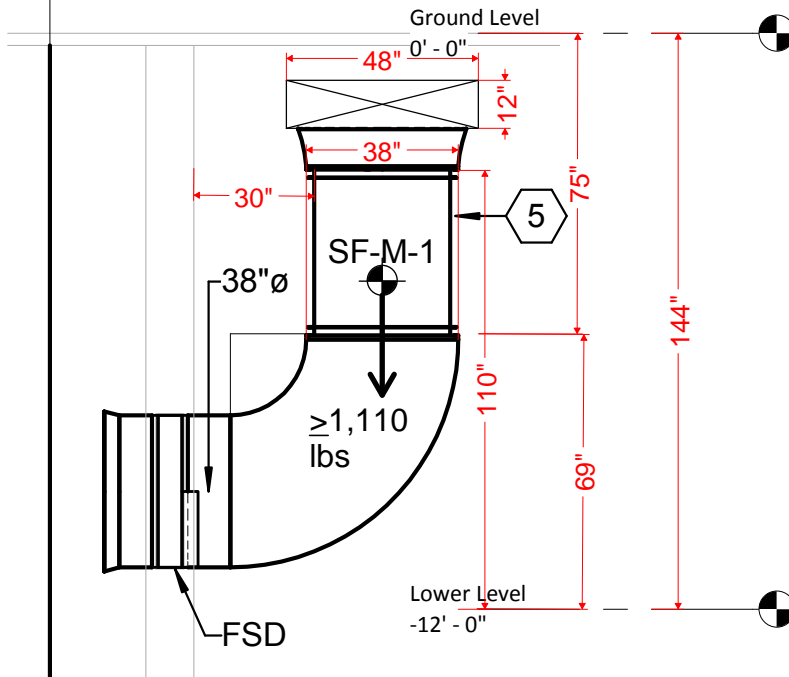

## 3 Section 8

1/4" = 1'-0"

### KEYED NOTES - M-200

- 5 PROVIDE NEW TEMPORARY VENTILATION INLINE FAN AT THE LOCATION SHOWN. SUPPORT FAN FROM FLOOR BELOW.

#### SCHEDULE - FAN

MARK	TYPE	DRIVE	CFM	E.S.P IN H2O	BRAKE HP	HP	POWER			FAN RPM	REMARKS
							VOLTS	PH	HZ		
SF-2-1	INLINE	DIRECT	400	0.35	0.07	1/6	120	1	60	940	GREENHECK MODEL SQ-VG NOTE 1,2,3
SF-M-1	INLINE	DIRECT	15000	0.5	8.49	10	460	3	60	1770	GREENHECK MODEL QEID NOTE 1









6	ADDENDUM 01	03/02/2018
1	ISSUE FOR PRICING	01/18/2018
No.	Description	Date

6	ADDENDUM 01	03/02/2018
1	ISSUE FOR PRICING	01/18/2018
No.	Description	Date

Keyplan



The University of Texas  
Health Science Center at  
Houston

**UCT  
SWITCHGEAR  
REPLACEMENT**

**ELECTRICAL ONE LINE  
DIAGRAMS -  
RENOVATION**

SSA Project Number	1095-027-01
Date	01/19/2018
Designed By	JCC
Checked By	FLP
Drawing No.	E030

Scale 12" = 1'-0"

**KEYED NOTES - E030**

- EXISTING 3000A BUSWAY SERVING EXISTING SWITCHBOARDS A, B & C, TO REMAIN UNTILL ALL EXISTING LOADS ARE TRANSFERED TO THE NEW SWITCHBOARDS MSBA & MSBB.
- 4#2/0, 2" CONCRETE ENCASED.
- 800A, 3 POLE, 480V ENCLOSED CIRCUIT BREAKER.
- 4#4/0, 2 1/2" CONCRETE ENCASED.
- 1100A, 3 POLE, 480V ENCLOSED CIRCUIT BREAKER.
- EXISTING FIRE PUMP CONTROLLER.
- PROVIDE NEW PULL BOX TO INTERCEPT EXISTING FEEDER. THIS CONTRACTOR SHALL VERIFY SIZE OF EXISTING CABLES PRIOR TO ORDER NEW CABLES AS SHOWN ON THIS ONE-LINE. NEW CABLES SHALL MATCH EXISTING.
- EXISTING TRANSFORMER IN EXISTING VAULT BY CPE TO REMAIN.
- EXISTING 400A, 480V, 3PH, 3W BUS PLUG ON LEVEL 24 SERVING NEW PANEL PHH IN PENTHOUSE. THIS CONTRACTOR SHALL INSTALL A NEW GROUND BUS IN EXISTING BUS PLUG AND INSTALL NEW #3 GND WIRE TO NEW GND BUS WALL MOUNTED.
- EXISTING 2-2 1/2" EACH WITH EXISTING 3-300KCMIL. THIS CONTRACTOR SHALL REMOVE EXISTING CABLES AND INSTALL NEW SETS OF 3#4/0, 1#3 GND IN EACH EXISTING 2 1/2".
- PROVIDE NEW GROUND BUS BAR WALL MOUNTED IN EXISTING ELECTRICAL ROOM 2 LEVEL 24. TERMINATE EXIST 350 GND, ALUMINUM WIRE IN NEW GROUND BUS BAR.
- THIS CONTRACTOR SHALL PROVIDE NEW PULL BOX TO INTERCEPT EXISTING FEEDER.
- EXISTING 2-3 1/2" EACH WITH NEW 4-350KCMIL, 1#2/0 GND AND 1-3 1/2" WITH NEW 4#4/0, 1#3 GND.
- NEW 2 1/2" WITH 4#4/0, 1#3 GND.
- NEW 2-3" CONDUIT EACH WITH 3-500KCMIL, 1#2/0 GND.
- KEY INTERLOCK MAIN-TIE-MAIN.
- THIS CONTRACTOR SHALL BID THE REPLACEMENT OF EXISTING MCC-1 AS ALTERNATE 01.
- THIS CONTRACTOR SHALL BID THE REPLACEMENT OF EXISTING PANEL PHH AS ALTERNATE 02.

**KEYED NOTES - E030**

- PROVIDE BREAKER WITH MOTORIZED ACTIVATION AND MAINTENANCE SWITCH FOR REMOTE OPERATING FEATURE. LOCATE SWITCH NEAR THE ENTRANCE TO THE ELECTRICAL ROOM.

**GENERAL NOTES - GE030**

- COORDINATE NEW WORK WITH EXISTING CONDITIONS.
- THIS CONTRACTOR SHALL NOTIFY UT HEALTH 3 WEEKS IN ADVANCE PRIOR TO EACH ELECTRICAL SHUTDOWN.
- REFER TO DRAWING E002A FOR ELECTRICAL SEQUENCE OF WORK.
- ALL NEW BREAKERS 1200A AND ABOVE SHALL BE ARC FLASH REDUCTION TYPE IN COMPLIANCE WITH NEC 240.87.
- THIS CONTRACTOR SHALL INSTALL A PERMANENTLY AFIXED LABEL AT ALL SWITCHGEARS, PANEL, AT'S, TRANSFORMERS, ETC WITH THE AVAILABLE FAULT CURRENT AT THE TIME OF INSTALLATION AND CALCULATION. THE LABEL SHALL BE 2"X 3" IN SIZE AND SHALL BE BLUE LETTERING ON A CONTRASTING BACKGROUND.
- THIS CONTRACTOR SHALL INSTALL NEW GROUND BUS BAR 1/2"x4"x20" IN EACH ELECTRICAL ROOM EAST & WEST FLOORS THRU 28 & PENTHOUSE WEST. BONDED LIGHTNING PROTECTION #5950-242412. REFER TO GROUNDING DIAGRAM E602.
- ALL CIRCUIT BREAKERS 600A AND ABOVE SHALL BE 100% RATED INCLUDING MAIN A, MAIN B & TIE.

**LOAD ANALYSIS**

LOAD	KVA
EXISTING PEAK KVA PER CPE 1.353KVAx1.25%	1,691
FUTURE LOAD	.800
TOTAL CONNECTED LOAD	2,491

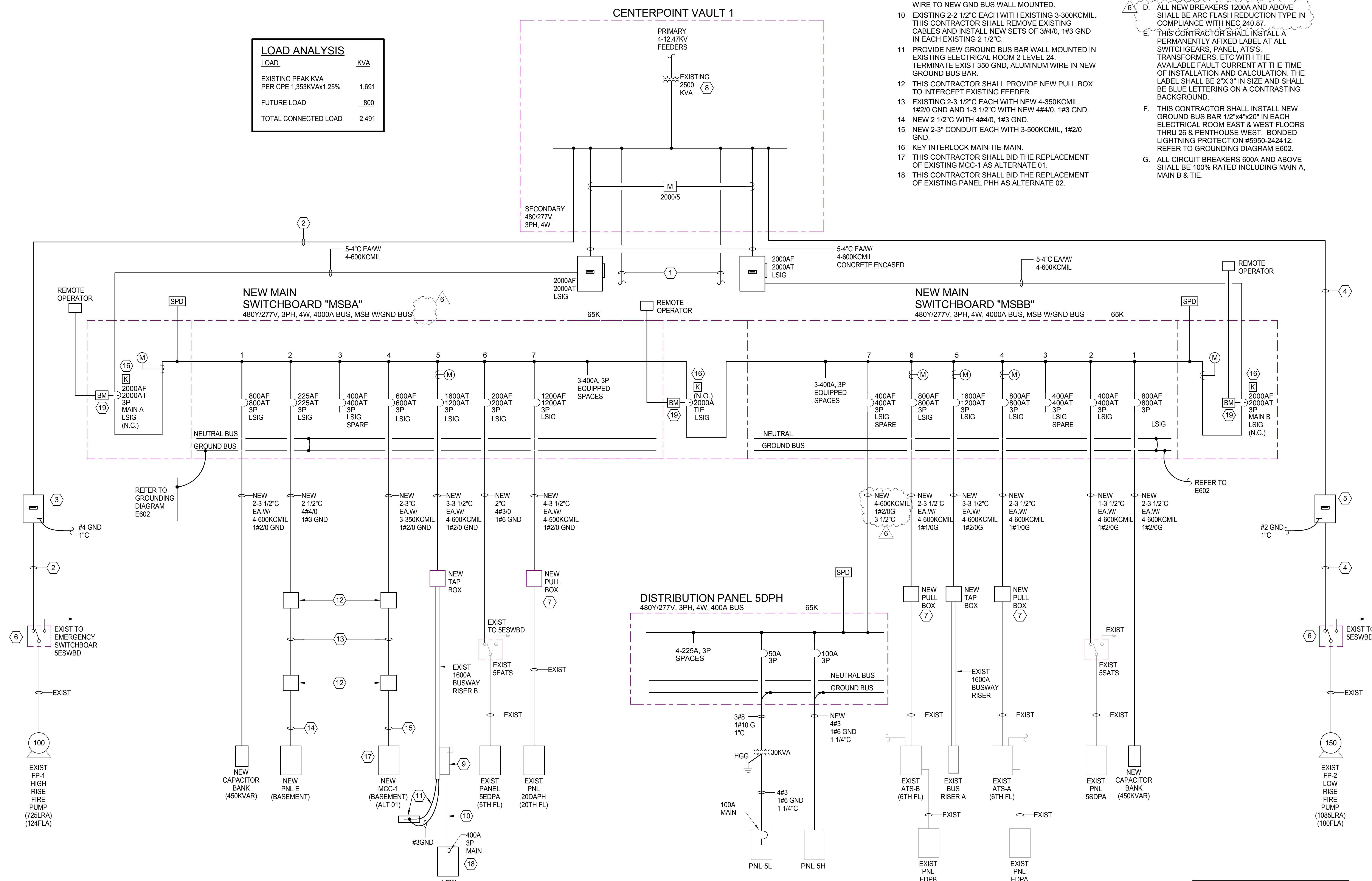

**UT HEALTH UTC - MSBA & MSBB - ONE  
LINE DIAGRAMS - RENOVATION**  
NO SCALE

**LINE TYPE LEGEND**

EXISTING	_____
NEW	_____



No.	Description	Date
2	Addendum 01	03/02/2018
1	Issue for Pricing	01/18/2018

Keyplan

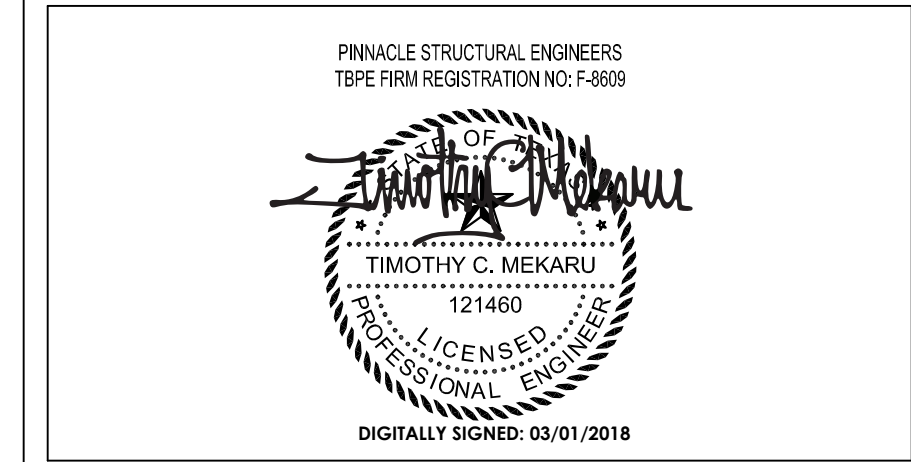

**UCT SWITCHGEAR REPLACEMENT**  
DETAILS

SSA Project Number	1095-027-01
Date	01/19/2018
Designed By	TM
Checked By	TM
Drawing No.	<b>S301</b>
Scale	AS SHOWN

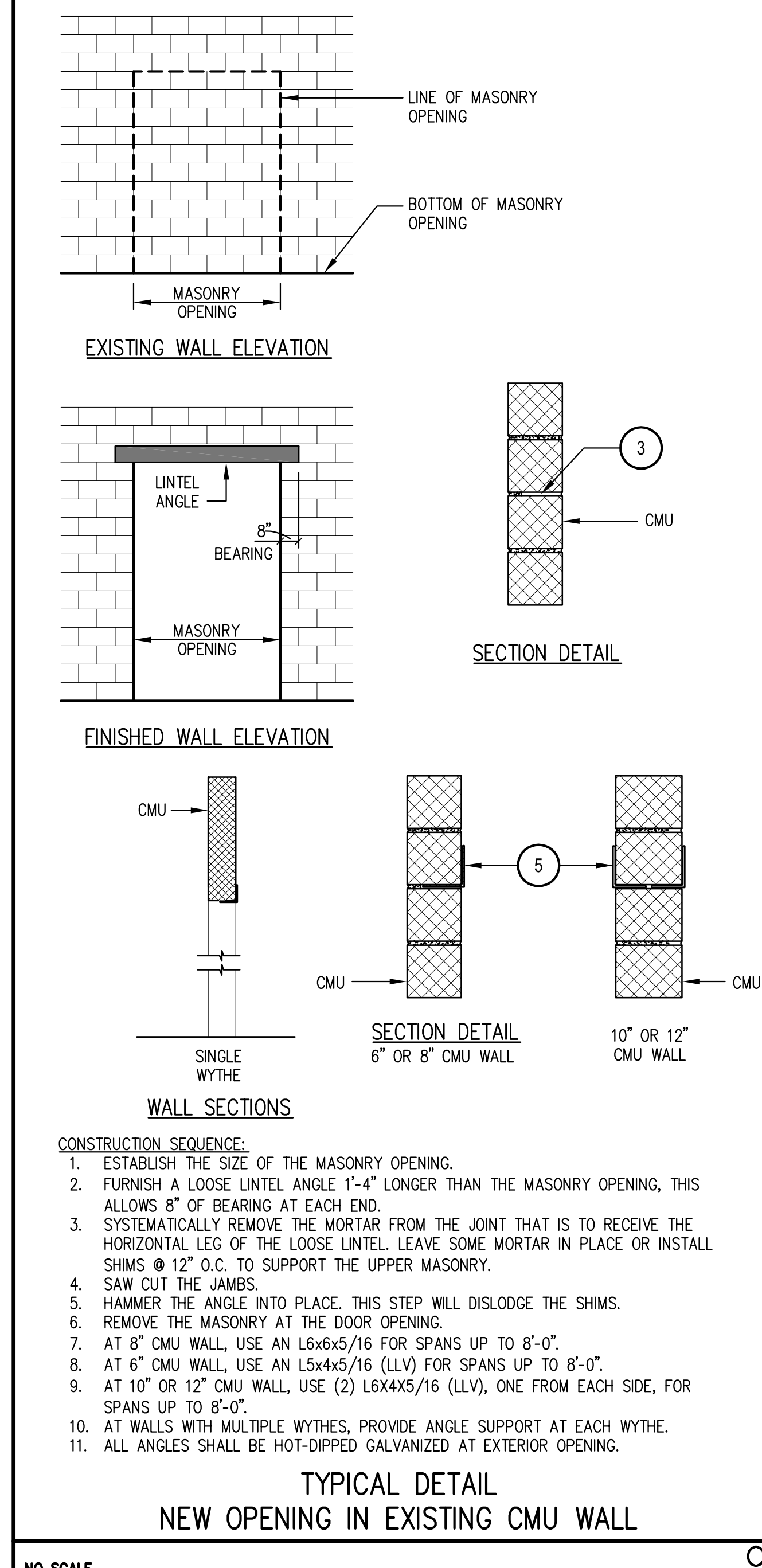
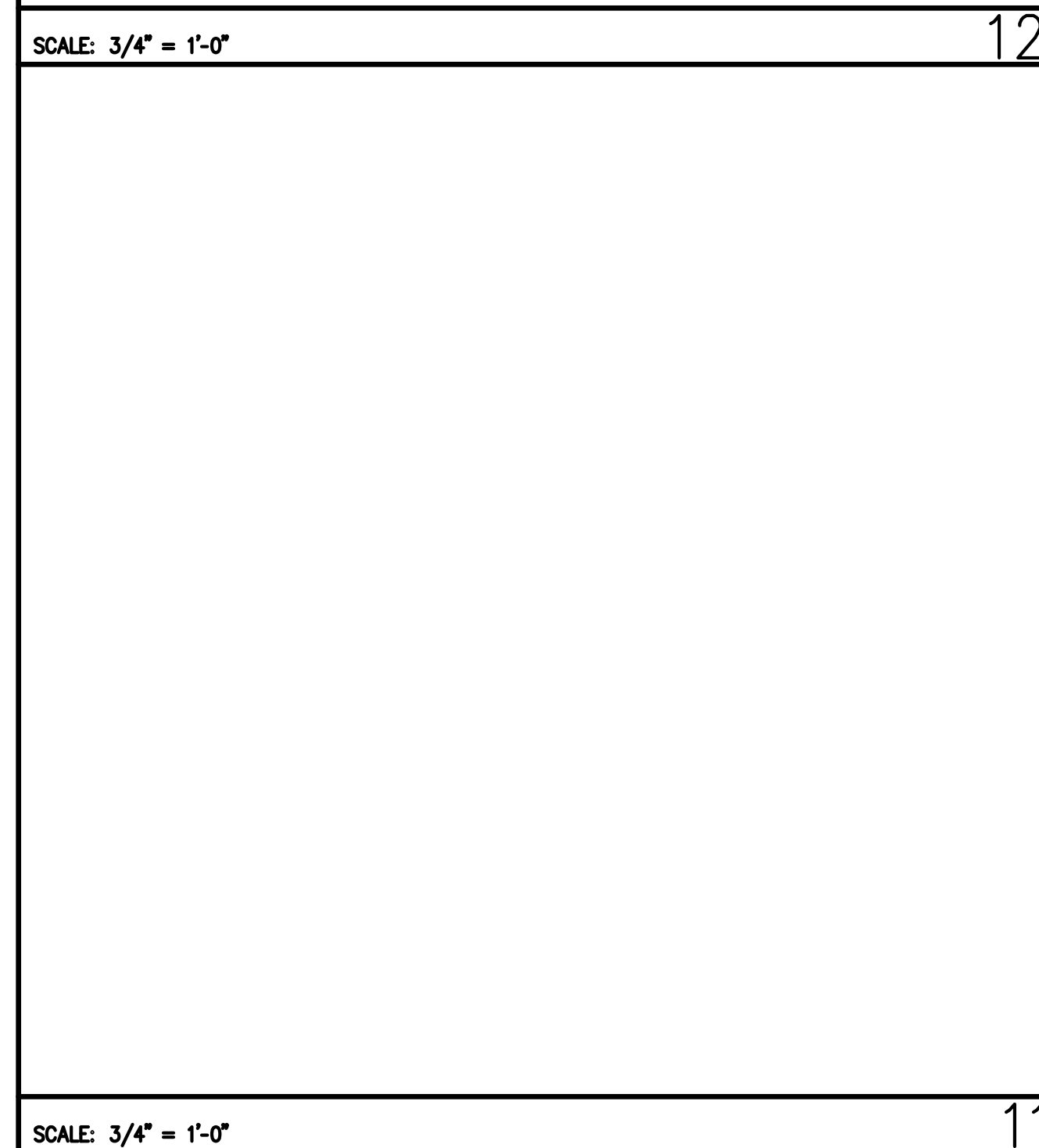
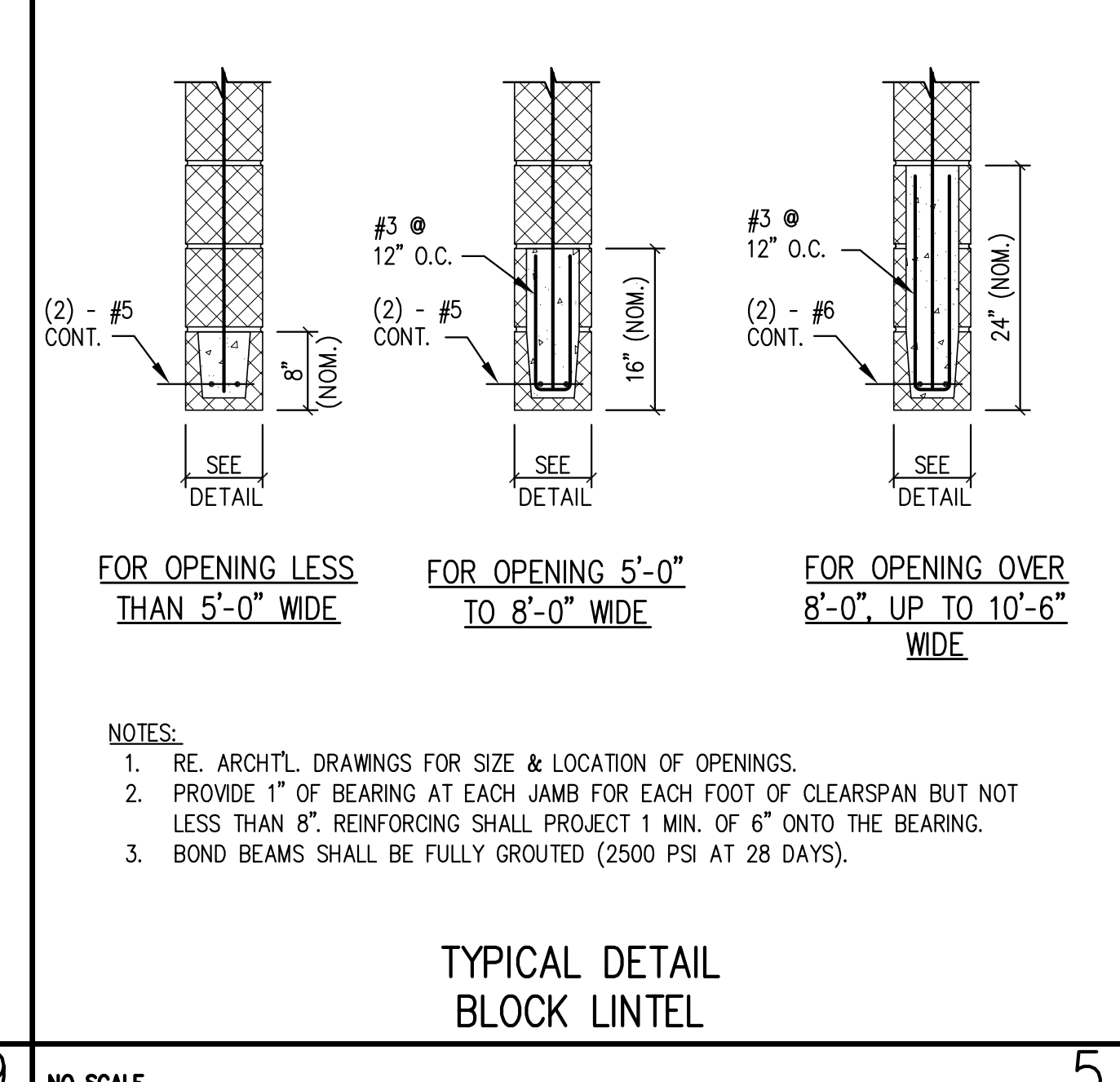
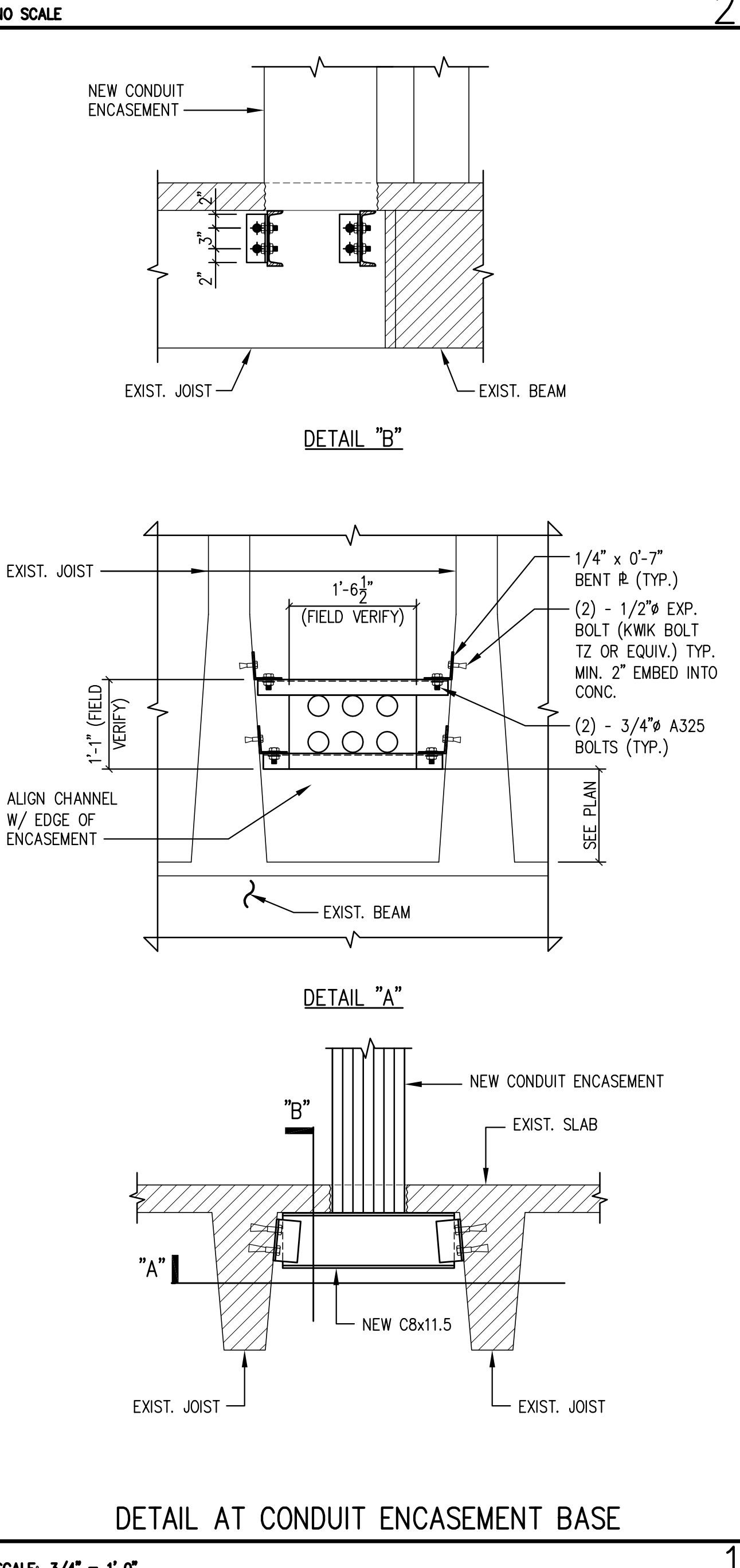
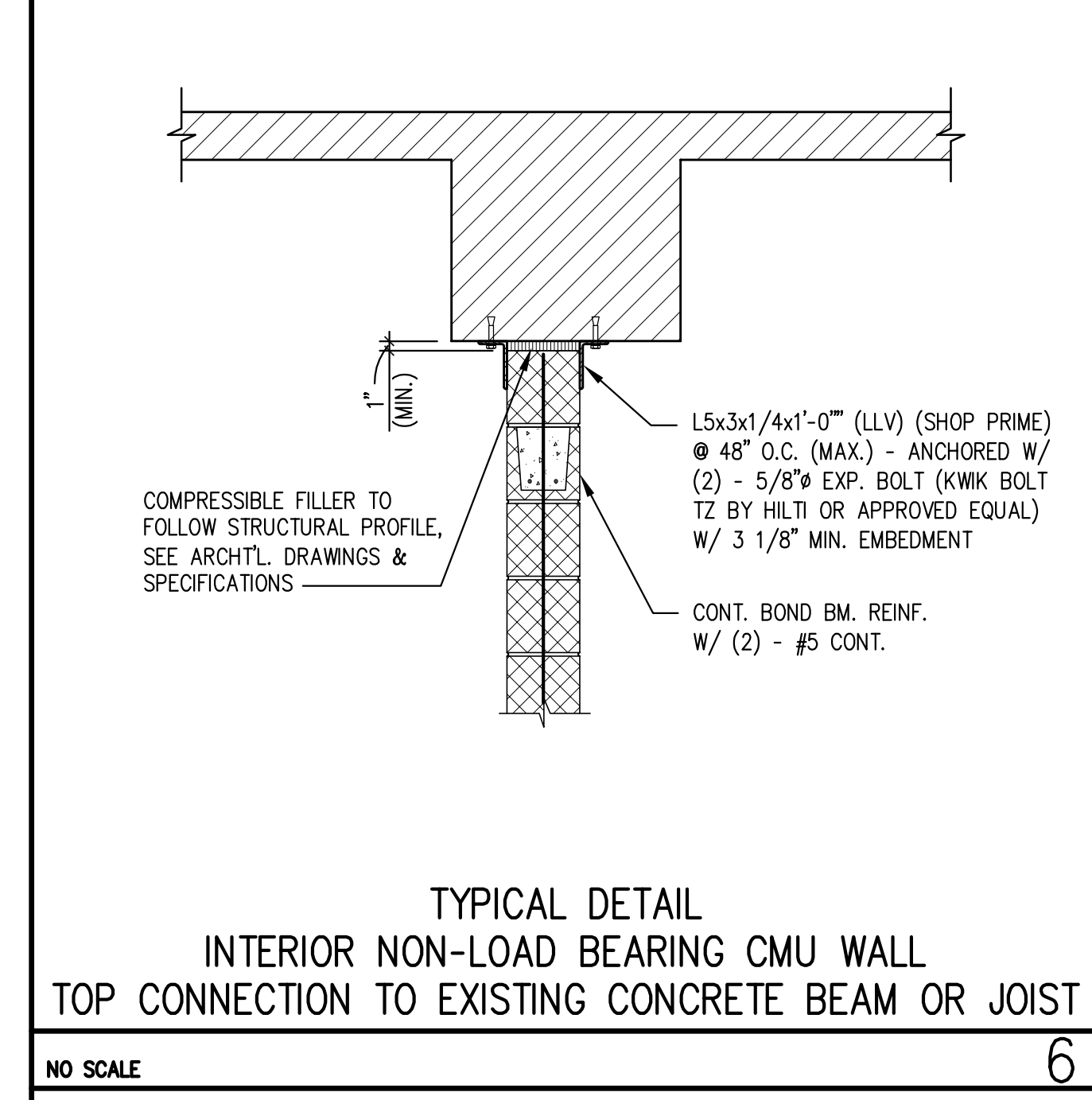
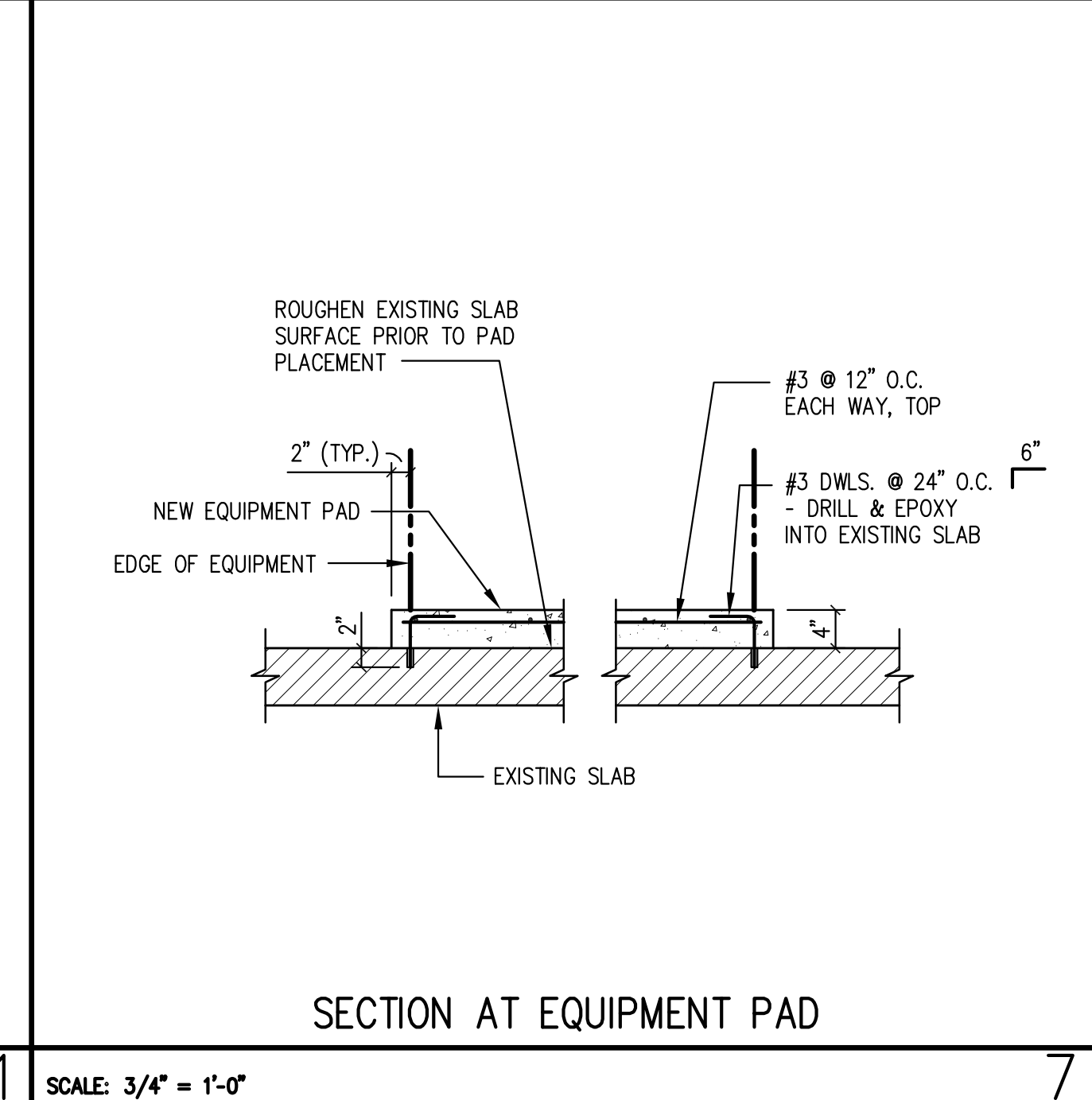
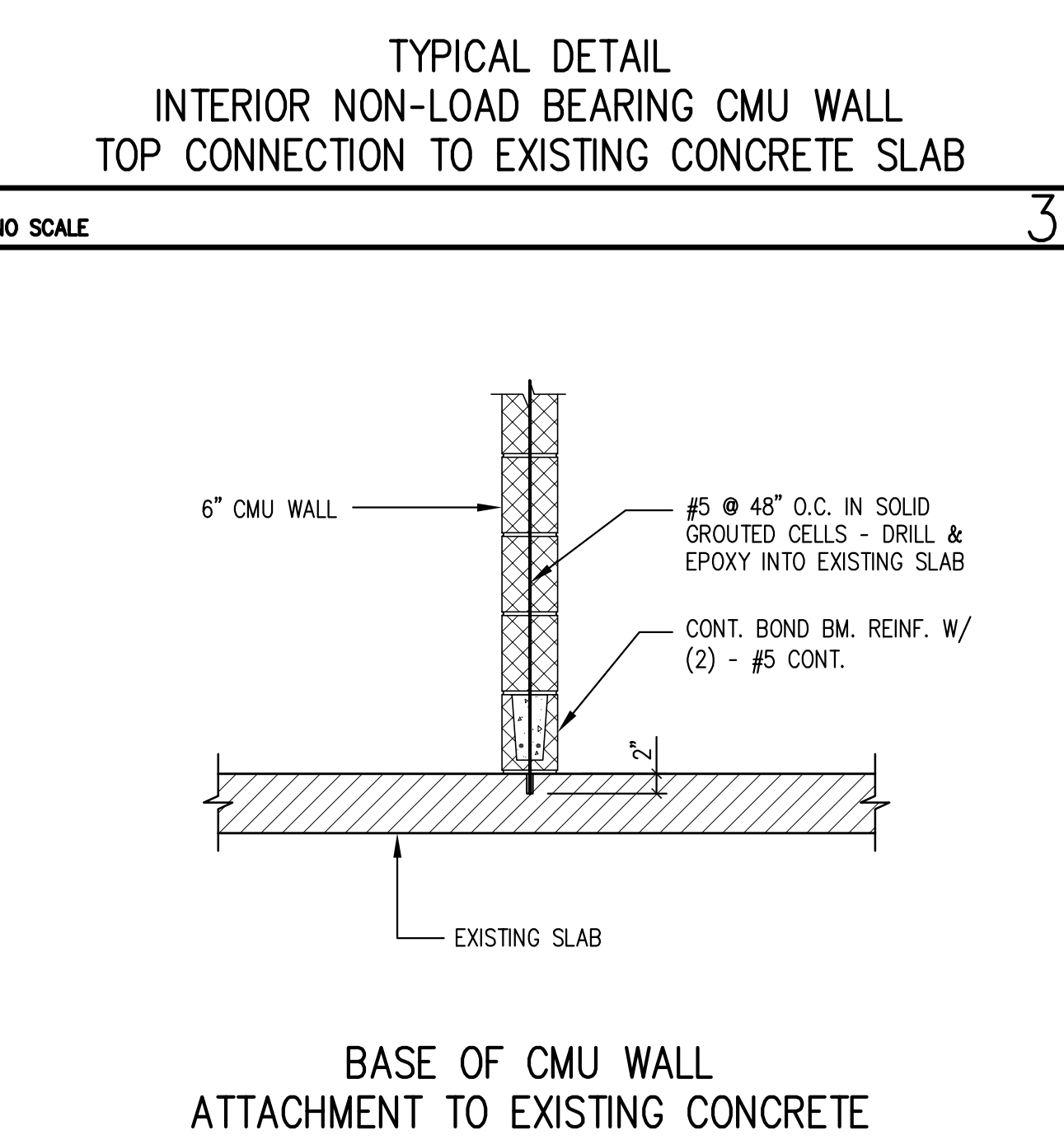
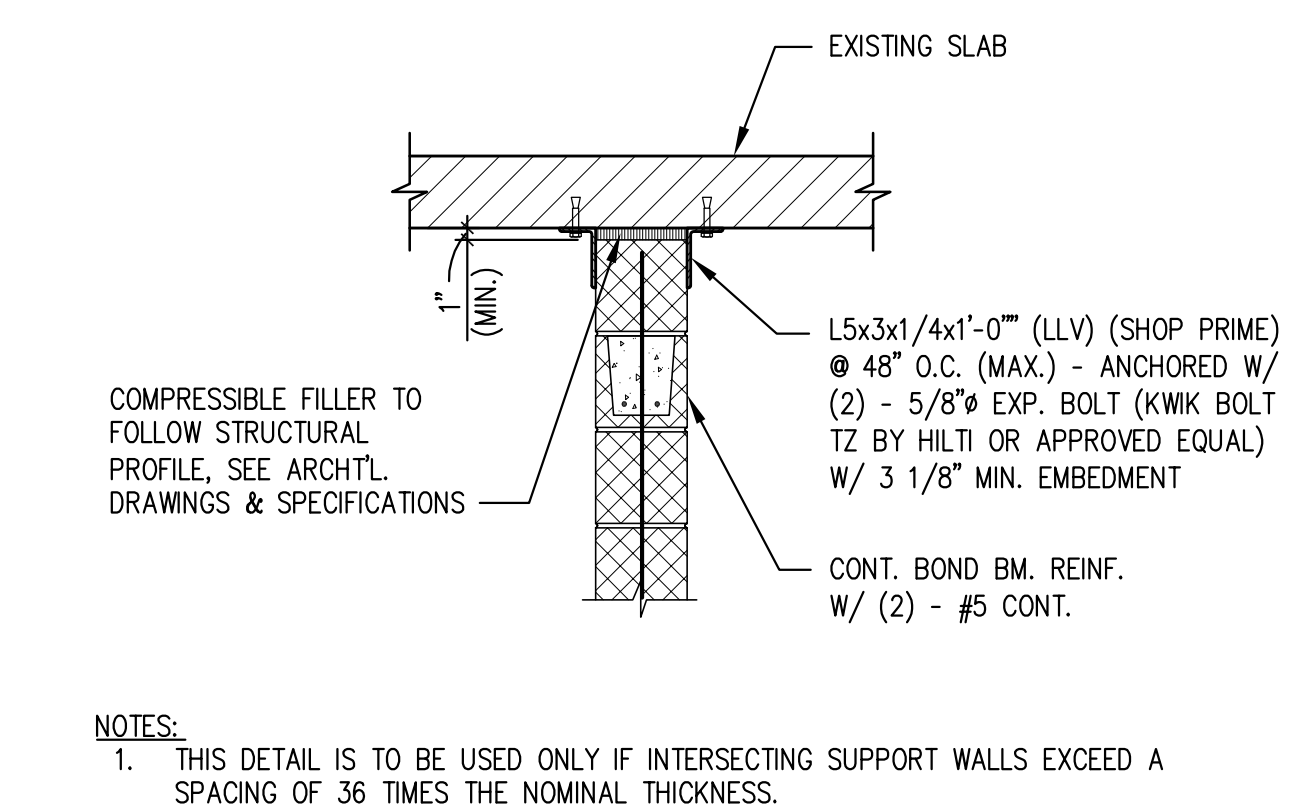
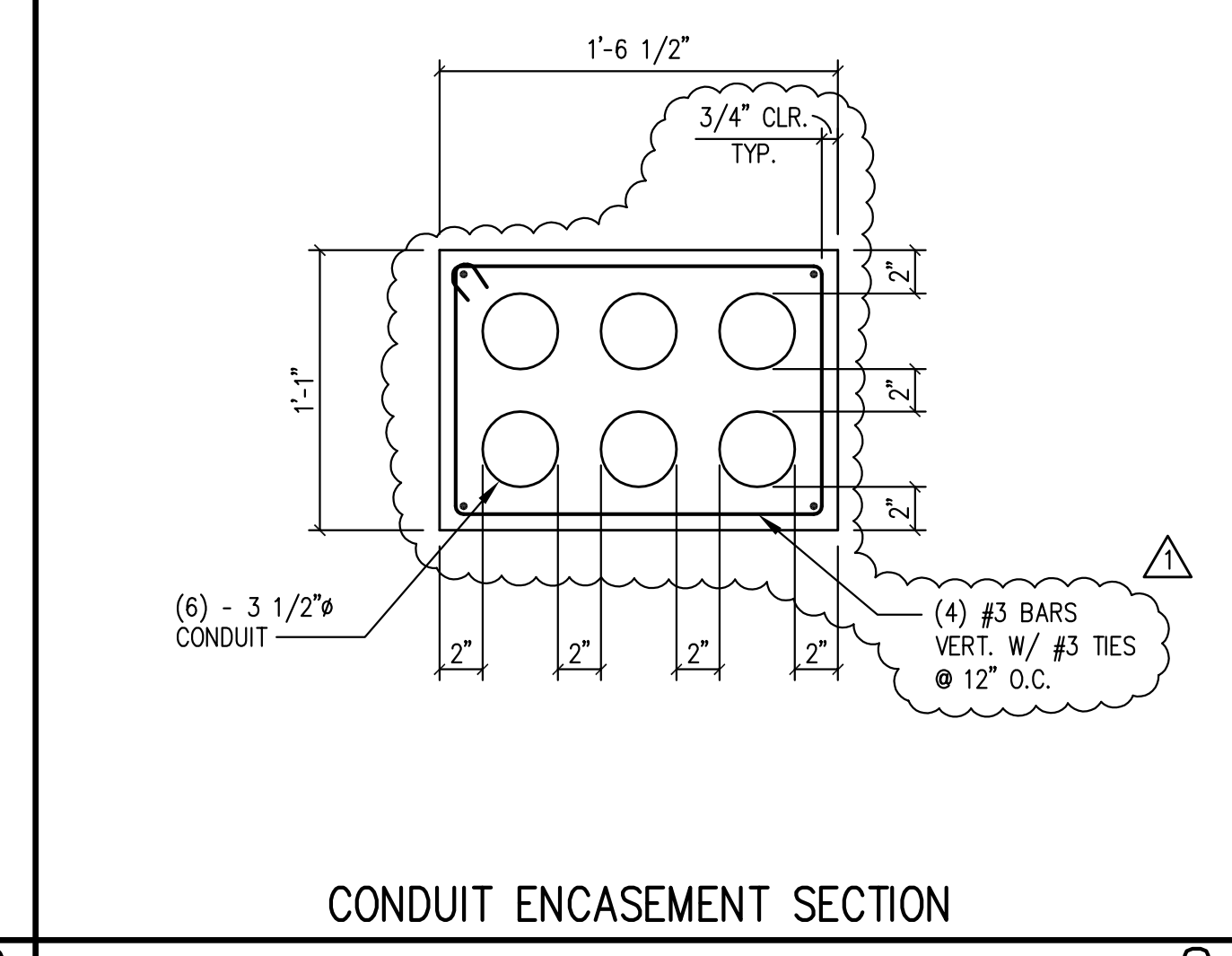

- CONSTRUCTION SEQUENCE:**
- ESTABLISH THE SIZE OF THE MASONRY OPENING.
  - FURNISH A LOOSE LINTEL ANGLE 1'-4" LONGER THAN THE MASONRY OPENING, THIS ALLOWS 8" OF BEARING AT EACH END. SYSTEMATICALLY REMOVE THE MORTAR FROM THE JOINT THAT IS TO RECEIVE THE HORIZONTAL LEG OF THE LOOSE LINTEL. LEAVE SOME MORTAR IN PLACE OR INSTALL SHIMS @ 12" O.C. TO SUPPORT THE UPPER MASONRY.
  - SAW CUT THE JAMBS.
  - HAMMER THE ANGLE INTO PLACE. THIS STEP WILL DISLODGE THE SHIMS.
  - REMOVE THE MASONRY AT THE DOOR OPENING.
  - AT 8" CMU WALL, USE AN L6x6x5/16 FOR SPANS UP TO 8'-0".
  - AT 6" CMU WALL, USE AN L5x4x5/16 (LLV) FOR SPANS UP TO 8'-0".
  - AT 10" OR 12" CMU WALL, USE (2) L6x4x5/16 (LLV), ONE FROM EACH SIDE, FOR SPANS UP TO 8'-0".
  - AT WALLS WITH MULTIPLE WYTHES, PROVIDE ANGLE SUPPORT AT EACH WYTHE.
  - ALL ANGLES SHALL BE HOT-DIPPED GALVANIZED AT EXTERIOR OPENING.

SCALE: 3/4" = 1'-0" 12

SCALE: 1 1/2" = 1'-0" 8

SCALE: 3/4" = 1'-0" 11

SCALE: 3/4" = 1'-0" 7

NO SCALE 9

NO SCALE 5

SCALE: 3/4" = 1'-0" 1



**TABLE OF CONTENTS**

**DIVISION 01 - GENERAL REQUIREMENTS**

01 30 00	ADMINISTRATIVE REQUIREMENTS.....	3
01 60 00	PRODUCT REQUIREMENTS.....	3
01 61 16	VOLATILE ORGANIC COMPOUND (VOC) CONTENT RESTRICTIONS.....	1
01 74 19	CONSTRUCTION WASTE MANAGEMENT AND DISPOSAL.....	3

**DIVISION 04 - MASONRY**

04 20 00	UNIT MASONRY.....	4
----------	-------------------	---

**DIVISION 07 - THERMAL AND MOISTURE PROTECTION**

07 84 00	FIRESTOPPING.....	3
07 92 00	JOINT SEALANTS.....	2

**DIVISION 08 - OPENINGS**

08 11 13	HOLLOW METAL DOORS AND FRAMES.....	4
08 71 00	DOOR HARDWARE.....	5

**DIVISION 09 - FINISHES**

09 21 16	GYPSUM BOARD ASSEMBLIES.....	9
09 91 13	EXTERIOR PAINTING.....	7
09 91 23	INTERIOR PAINTING.....	1
09 96 00	HIGH-PERFORMANCE COATINGS.....	3
09 97 23	CONCRETE AND MASONRY COATINGS.....	2



**SECTION 01 30 00**  
**ADMINISTRATIVE REQUIREMENTS**

**PART 1 GENERAL**

**1.01 SECTION INCLUDES**

- A. Electronic document submittal service.
- B. Preconstruction meeting.
- C. Progress meetings.
- D. Submittals for review, information, and project closeout.
- E. Submittal procedures.

**PART 2 PRODUCTS - NOT USED**

**PART 3 EXECUTION**

**3.01 ELECTRONIC DOCUMENT SUBMITTAL SERVICE**

- A. All documents transmitted for purposes of administration of the contract are to be in electronic (PDF) format and transmitted via an Internet-based submittal service that receives, logs and stores documents, provides electronic stamping and signatures, and notifies addressees via email.
  - 1. Besides submittals for review, information, and closeout, this procedure applies to requests for information (RFIs), progress documentation, contract modification documents (e.g. supplementary instructions, change proposals, change orders), applications for payment, field reports and meeting minutes, Contractor's correction punchlist, and any other document any participant wishes to make part of the project record.
  - 2. Contractor and Architect are required to use this service.
  - 3. It is Contractor's responsibility to submit documents in PDF format.
  - 4. Subcontractors, suppliers, and Architect's consultants will be permitted to use the service at no extra charge.
  - 5. Users of the service need an email address, Internet access, and PDF review software that includes ability to mark up and apply electronic stamps (such as Adobe Acrobat, [www.adobe.com](http://www.adobe.com), or Bluebeam PDF Revu, [www.bluebeam.com](http://www.bluebeam.com)), unless such software capability is provided by the service provider.
  - 6. Paper document transmittals will not be reviewed; emailed PDF documents will not be reviewed.
  - 7. All other specified submittal and document transmission procedures apply, except that electronic document requirements do not apply to samples or color selection charts.
- B. Submittal Service: The selected service is:
- C. Training: One, one-hour, web-based training session will be arranged for all participants, with representatives of Architect and Contractor participating; further training is the responsibility of the user of the service.
- D. Project Closeout: Architect will determine when to terminate the service for the project and is responsible for obtaining archive copies of files for Owner.

**3.02 PROGRESS MEETINGS**

- A. Attendance Required:
  - 1. Contractor.
  - 2. Owner.
  - 3. Architect.
  - 4. Contractor's Superintendent.
  - 5. Major Subcontractors.

- B. Agenda:
1. Review minutes of previous meetings.
  2. Review of Work progress.
  3. Field observations, problems, and decisions.
  4. Identification of problems that impede, or will impede, planned progress.
  5. Review of submittals schedule and status of submittals.
  6. Maintenance of progress schedule.
  7. Corrective measures to regain projected schedules.
  8. Planned progress during succeeding work period.
  9. Maintenance of quality and work standards.
  10. Effect of proposed changes on progress schedule and coordination.
  11. Other business relating to Work.
- C. Record minutes and distribute copies within two days after meeting to participants, with two copies to Architect, Owner, participants, and those affected by decisions made.

### **3.03 SUBMITTALS FOR REVIEW**

- A. When the following are specified in individual sections, submit them for review:
1. Product data.
  2. Shop drawings.
  3. Samples for selection.
  4. Samples for verification.
- B. Submit to Architect for review for the limited purpose of checking for conformance with information given and the design concept expressed in the contract documents.
- C. Samples will be reviewed only for aesthetic, color, or finish selection.
- D. After review, provide copies and distribute in accordance with SUBMITTAL PROCEDURES article below and for record documents purposes described in Section 01 78 00 - Closeout Submittals.

### **3.04 SUBMITTALS FOR INFORMATION**

- A. When the following are specified in individual sections, submit them for information:
1. Design data.
  2. Certificates.
  3. Test reports.
  4. Inspection reports.
  5. Manufacturer's instructions.
  6. Manufacturer's field reports.
  7. Other types indicated.
- B. Submit for Architect's knowledge as contract administrator or for Owner. No action will be taken.

### **3.05 SUBMITTALS FOR PROJECT CLOSEOUT**

- A. Submit Correction Punch List for Substantial Completion.
- B. Submit Final Correction Punch List for Substantial Completion.
- C. When the following are specified in individual sections, submit them at project closeout:
1. Project record documents.
  2. Operation and maintenance data.
  3. Warranties.
  4. Bonds.
  5. Other types as indicated.
- D. Submit for Owner's benefit during and after project completion.

### **3.06 NUMBER OF COPIES OF SUBMITTALS**

- A. Electronic Documents: Submit one electronic copy in PDF format; an electronically-marked up file will be returned. Create PDFs at native size and right-side up; illegible files will be rejected.
- B. Samples: Submit the number specified in individual specification sections; one of which will be retained by Architect.
  - 1. After review, produce duplicates.
  - 2. Retained samples will not be returned to Contractor unless specifically so stated.

### **3.07 SUBMITTAL PROCEDURES**

- A. Shop Drawing Procedures:
  - 1. Prepare accurate, drawn-to-scale, original shop drawing documentation by interpreting the Contract Documents and coordinating related Work.
  - 2. Generic, non-project specific information submitted as shop drawings do not meet the requirements for shop drawings.
- B. Transmit each submittal with a copy of approved submittal form.
- C. Sequentially number the transmittal form. Revise submittals with original number and a sequential alphabetic suffix.
- D. Identify Project, Contractor, Subcontractor or supplier; pertinent drawing and detail number, and specification section number, as appropriate on each copy.
- E. Apply Contractor's stamp, signed or initialed certifying that review, approval, verification of Products required, field dimensions, adjacent construction Work, and coordination of information is in accordance with the requirements of the Work and Contract Documents.
- F. Schedule submittals to expedite the Project, and coordinate submission of related items.
- G. For each submittal for review, allow 15 days excluding delivery time to and from the Contractor.
- H. Identify variations from Contract Documents and Product or system limitations that may be detrimental to successful performance of the completed Work.
- I. Provide space for Contractor and Architect review stamps.
- J. When revised for resubmission, identify all changes made since previous submission.
- K. Distribute reviewed submittals as appropriate. Instruct parties to promptly report any inability to comply with requirements.
- L. Submittals not requested will not be recognized or processed.

**END OF SECTION**

**SECTION 01 60 00**  
**PRODUCT REQUIREMENTS**

**PART 1 GENERAL**

**1.01 SECTION INCLUDES**

- A. Re-use of existing products.
- B. Transportation, handling, storage and protection.
- C. Product option requirements.
- D. Substitution limitations and procedures.
- E. Maintenance materials, including extra materials, spare parts, tools, and software.

**1.02 RELATED REQUIREMENTS**

- A. Section 01 61 16 - Volatile Organic Compound (VOC) Content Restrictions: Requirements for VOC-restricted product categories.
- B. Section 01 74 19 - Construction Waste Management and Disposal: Waste disposal requirements potentially affecting packaging and substitutions.

**1.03 SUBMITTALS**

- A. Product Data Submittals: Submit manufacturer's standard published data. Mark each copy to identify applicable products, models, options, and other data. Supplement manufacturers' standard data to provide information specific to this Project.
- B. Shop Drawing Submittals: Prepared specifically for this Project; indicate utility and electrical characteristics, utility connection requirements, and location of utility outlets for service for functional equipment and appliances.
- C. Sample Submittals: Illustrate functional and aesthetic characteristics of the product, with integral parts and attachment devices. Coordinate sample submittals for interfacing work.
  - 1. For selection from standard finishes, submit samples of the full range of the manufacturer's standard colors, textures, and patterns.

**PART 2 PRODUCTS**

**2.01 EXISTING PRODUCTS**

- A. Do not use materials and equipment removed from existing premises unless specifically required or permitted by the Contract Documents.
- B. Unforeseen historic items encountered remain the property of the Owner; notify Owner promptly upon discovery; protect, remove, handle, and store as directed by Owner.

**2.02 NEW PRODUCTS**

- A. Provide new products unless specifically required or permitted by the Contract Documents.
- B. DO NOT USE products having any of the following characteristics:
  - 1. Made outside the United States, its territories, Canada, or Mexico.
  - 2. Made using or containing CFC's or HCFC's.
  - 3. Made of wood from newly cut old growth timber.
  - 4. Containing lead, cadmium, asbestos.
- C. Where all other criteria are met, Contractor shall give preference to products that:
  - 1. If used on interior, have lower emissions, as defined in Section 01 61 16.
  - 2. If wet-applied, have lower VOC content, as defined in Section 01 61 16.
  - 3. Have a published GreenScreen Chemical Hazard Analysis.

### **2.03 PRODUCT OPTIONS**

- A. Products Specified by Reference Standards or by Description Only: Use any product meeting those standards or description.
- B. Products Specified by Naming One or More Manufacturers: Use a product of one of the manufacturers named and meeting specifications, no options or substitutions allowed.
- C. Products Specified by Naming One or More Manufacturers with a Provision for Substitutions: Submit a request for substitution for any manufacturer not named.

### **2.04 MAINTENANCE MATERIALS**

- A. Furnish extra materials, spare parts, tools, and software of types and in quantities specified in individual specification sections.
- B. Deliver to Project site; obtain receipt prior to final payment.

## **PART 3 EXECUTION**

### **3.01 SUBSTITUTION PROCEDURES**

- A. Document each request with complete data substantiating compliance of proposed substitution with Contract Documents.
- B. A request for substitution constitutes a representation that the submitter:
  - 1. Has investigated proposed product and determined that it meets or exceeds the quality level of the specified product.
  - 2. Agrees to provide the same warranty for the substitution as for the specified product.
  - 3. Agrees to coordinate installation and make changes to other Work that may be required for the Work to be complete with no additional cost to Owner.
  - 4. Waives claims for additional costs or time extension that may subsequently become apparent.

### **3.02 TRANSPORTATION AND HANDLING**

- A. Package products for shipment in manner to prevent damage; for equipment, package to avoid loss of factory calibration.
- B. If special precautions are required, attach instructions prominently and legibly on outside of packaging.
- C. Coordinate schedule of product delivery to designated prepared areas in order to minimize site storage time and potential damage to stored materials.
- D. Transport and handle products in accordance with manufacturer's instructions.
- E. Transport materials in covered trucks to prevent contamination of product and littering of surrounding areas.
- F. Promptly inspect shipments to ensure that products comply with requirements, quantities are correct, and products are undamaged.
- G. Provide equipment and personnel to handle products by methods to prevent soiling, disfigurement, or damage, and to minimize handling.
- H. Arrange for the return of packing materials, such as wood pallets, where economically feasible.

### **3.03 STORAGE AND PROTECTION**

- A. Designate receiving/storage areas for incoming products so that they are delivered according to installation schedule and placed convenient to work area in order to minimize waste due to excessive materials handling and misapplication.
- B. Store and protect products in accordance with manufacturers' instructions.
- C. Store with seals and labels intact and legible.

- D. Store sensitive products in weather tight, climate controlled, enclosures in an environment favorable to product.
- E. For exterior storage of fabricated products, place on sloped supports above ground.
- F. Protect products from damage or deterioration due to construction operations, weather, precipitation, humidity, temperature, sunlight and ultraviolet light, dirt, dust, and other contaminants.
- G. Comply with manufacturer's warranty conditions, if any.
- H. Cover products subject to deterioration with impervious sheet covering. Provide ventilation to prevent condensation and degradation of products.
- I. Prevent contact with material that may cause corrosion, discoloration, or staining.
- J. Provide equipment and personnel to store products by methods to prevent soiling, disfigurement, or damage.
- K. Arrange storage of products to permit access for inspection. Periodically inspect to verify products are undamaged and are maintained in acceptable condition.

**END OF SECTION**

**SECTION 01 61 16**

**VOLATILE ORGANIC COMPOUND (VOC) CONTENT RESTRICTIONS**

**PART 1 GENERAL**

**1.01 SECTION INCLUDES**

**1.02 RELATED REQUIREMENTS**

- A. Section 01 30 00 - Administrative Requirements: Submittal procedures.
- B. Section 01 60 00 - Product Requirements: Fundamental product requirements, substitutions and product options, delivery, storage, and handling.

**1.03 DEFINITIONS**

- A. Interior of Building: Anywhere inside the exterior weather barrier.

**1.04 SUBMITTALS**

- A. See Section 01 30 00 - Administrative Requirements, for submittal procedures.
- B. Product Data: For each VOC-restricted product used in the project, submit evidence of compliance.

**PART 2 PRODUCTS**

**2.01 MATERIALS**

- A. All Products: Comply with the most stringent of federal, State, and local requirements, or these specifications.

**PART 3 EXECUTION**

**3.01 FIELD QUALITY CONTROL**

- A. Owner reserves the right to reject non-compliant products, whether installed or not, and require their removal and replacement with compliant products at no extra cost to Owner.
- B. Additional costs to restore indoor air quality due to installation of non-compliant products will be borne by Contractor.

**END OF SECTION**



**SECTION 01 74 19**

**CONSTRUCTION WASTE MANAGEMENT AND DISPOSAL**

**PART 1 GENERAL**

**1.01 WASTE MANAGEMENT REQUIREMENTS**

- A. Owner requires that this project generate the least amount of trash and waste possible.
- B. Employ processes that ensure the generation of as little waste as possible due to error, poor planning, breakage, mishandling, contamination, or other factors.
- C. Minimize trash/waste disposal in landfills; reuse, salvage, or recycle as much waste as economically feasible.
- D. Contractor shall submit periodic Waste Disposal Reports; all landfill disposal, incineration, recycling, salvage, and reuse must be reported regardless of to whom the cost or savings accrues; use the same units of measure on all reports.
- E. Methods of trash/waste disposal that are not acceptable are:
  - 1. Burning on the project site.
  - 2. Burying on the project site.
  - 3. Dumping or burying on other property, public or private.
  - 4. Other illegal dumping or burying.
- F. Regulatory Requirements: Contractor is responsible for knowing and complying with regulatory requirements, including but not limited to Federal, state and local requirements, pertaining to legal disposal of all construction and demolition waste materials.

**1.02 DEFINITIONS**

- A. Clean: Untreated and unpainted; not contaminated with oils, solvents, caulk, or the like.
- B. Construction and Demolition Waste: Solid wastes typically including building materials, packaging, trash, debris, and rubble resulting from construction, remodeling, repair and demolition operations.
- C. Hazardous: Exhibiting the characteristics of hazardous substances, i.e., ignitibility, corrosivity, toxicity or reactivity.
- D. Nonhazardous: Exhibiting none of the characteristics of hazardous substances, i.e., ignitibility, corrosivity, toxicity, or reactivity.
- E. Nontoxic: Neither immediately poisonous to humans nor poisonous after a long period of exposure.
- F. Recyclable: The ability of a product or material to be recovered at the end of its life cycle and remanufactured into a new product for reuse by others.
- G. Recycle: To remove a waste material from the project site to another site for remanufacture into a new product for reuse by others.
- H. Recycling: The process of sorting, cleansing, treating and reconstituting solid waste and other discarded materials for the purpose of using the altered form. Recycling does not include burning, incinerating, or thermally destroying waste.
- I. Return: To give back reusable items or unused products to vendors for credit.
- J. Reuse: To reuse a construction waste material in some manner on the project site.
- K. Salvage: To remove a waste material from the project site to another site for resale or reuse by others.
- L. Sediment: Soil and other debris that has been eroded and transported by storm or well production run-off water.

- M. Source Separation: The act of keeping different types of waste materials separate beginning from the first time they become waste.
- N. Toxic: Poisonous to humans either immediately or after a long period of exposure.
- O. Trash: Any product or material unable to be reused, returned, recycled, or salvaged.
- P. Waste: Extra material or material that has reached the end of its useful life in its intended use. Waste includes salvageable, returnable, recyclable, and reusable material.

### 1.03 SUBMITTALS

- A. See Section 01 30 00 - Administrative Requirements, for submittal procedures.
- B. Waste Disposal Reports: Submit at specified intervals, with details of quantities of trash and waste, means of disposal or reuse, and costs; show both totals to date and since last report.
  - 1. Submit updated Report with each Application for Progress Payment; failure to submit Report will delay payment.
  - 2. Submit Report on a form acceptable to Owner.
  - 3. Landfill Disposal: Include the following information:
    - a. Identification of material.
    - b. Amount, in tons or cubic yards, of trash/waste material from the project disposed of in landfills.
    - c. State the identity of landfills, total amount of tipping fees paid to landfill, and total disposal cost.
    - d. Include manifests, weight tickets, receipts, and invoices as evidence of quantity and cost.
  - 4. Incinerator Disposal: Include the following information:
    - a. Identification of material.
    - b. Amount, in tons or cubic yards, of trash/waste material from the project delivered to incinerators.
    - c. State the identity of incinerators, total amount of fees paid to incinerator, and total disposal cost.
    - d. Include manifests, weight tickets, receipts, and invoices as evidence of quantity and cost.
  - 5. Recycled and Salvaged Materials: Include the following information for each:
    - a. Identification of material, including those retrieved by installer for use on other projects.
    - b. Amount, in tons or cubic yards, date removed from the project site, and receiving party.
    - c. Transportation cost, amount paid or received for the material, and the net total cost or savings of salvage or recycling each material.
    - d. Include manifests, weight tickets, receipts, and invoices as evidence of quantity and cost.
    - e. Certification by receiving party that materials will not be disposed of in landfills or by incineration.
  - 6. Material Reused on Project: Include the following information for each:
    - a. Identification of material and how it was used in the project.
    - b. Amount, in tons or cubic yards.
    - c. Include weight tickets as evidence of quantity.
  - 7. Other Disposal Methods: Include information similar to that described above, as appropriate to disposal method.

### **PART 3 EXECUTION**

#### **2.01 WASTE MANAGEMENT PROCEDURES**

- A. See Section 01 30 00 for additional requirements for project meetings, reports, submittal procedures, and project documentation.
- B. See Section 01 50 00 for additional requirements related to trash/waste collection and removal facilities and services.
- C. See Section 01 60 00 for waste prevention requirements related to delivery, storage, and handling.
- D. See Section 01 70 00 for trash/waste prevention procedures related to demolition, cutting and patching, installation, protection, and cleaning.

#### **2.02 WASTE MANAGEMENT PLAN IMPLEMENTATION**

- A. Manager: Designate an on-site person or persons responsible for instructing workers and overseeing and documenting results of the Waste Management Plan.
- B. Communication: Distribute copies of the Waste Management Plan to job site foreman, each subcontractor, Owner, and Architect.
- C. Instruction: Provide on-site instruction of appropriate separation, handling, and recycling, salvage, reuse, and return methods to be used by all parties at the appropriate stages of the project.
- D. Meetings: Discuss trash/waste management goals and issues at project meetings.
  - 1. Pre-bid meeting.
  - 2. Pre-construction meeting.
  - 3. Regular job-site meetings.
- E. Facilities: Provide specific facilities for separation and storage of materials for recycling, salvage, reuse, return, and trash disposal, for use by all contractors and installers.
  - 1. Provide containers as required.
  - 2. Provide adequate space for pick-up and delivery and convenience to subcontractors.
  - 3. Keep recycling and trash/waste bin areas neat and clean and clearly marked in order to avoid contamination of materials.
- F. Hazardous Wastes: Separate, store, and dispose of hazardous wastes according to applicable regulations.
- G. Recycling: Separate, store, protect, and handle at the site identified recyclable waste products in order to prevent contamination of materials and to maximize recyclability of identified materials. Arrange for timely pickups from the site or deliveries to recycling facility in order to prevent contamination of recyclable materials.
- H. Reuse of Materials On-Site: Set aside, sort, and protect separated products in preparation for reuse.
- I. Salvage: Set aside, sort, and protect products to be salvaged for reuse off-site.

**END OF SECTION**

**SECTION 04 20 00**  
**UNIT MASONRY**

**PART 1 GENERAL**

**1.01 SECTION INCLUDES**

- A. Concrete Block.
- B. Mortar and Grout.
- C. Reinforcement and Anchorage.
- D. Accessories.

**1.02 RELATED REQUIREMENTS**

- A. Section 03 20 00 - Concrete Reinforcing: Reinforcing steel for grouted masonry.
- B. Section 04 05 11 - Mortar and Masonry Grout.

**1.03 REFERENCE STANDARDS**

- A. ACI 530/530.1/ERTA - Building Code Requirements and Specification for Masonry Structures and Related Commentaries; 2011.
- B. ASTM A615/A615M - Standard Specification for Deformed and Plain Carbon Steel Bars for Concrete Reinforcement; 2015.
- C. ASTM A641/A641M - Standard Specification for Zinc-Coated (Galvanized) Carbon Steel Wire; 2009a (Reapproved 2014).
- D. ASTM A653/A653M - Standard Specification for Steel Sheet, Zinc-Coated (Galvanized) or Zinc-Iron Alloy-Coated (Galvannealed) by the Hot-Dip Process; 2015.
- E. ASTM A1064/A1064M - Standard Specification for Carbon-Steel Wire and Welded Wire Reinforcement, Plain and Deformed, for Concrete; 2015.
- F. ASTM C129 - Standard Specification for Nonloadbearing Concrete Masonry Units; 2011.
- G. ASTM C140/C140M - Standard Test Methods of Sampling and Testing Concrete Masonry Units and Related Units; 2014.
- H. ASTM C144 - Standard Specification for Aggregate for Masonry Mortar; 2011.
- I. ASTM C150/C150M - Standard Specification for Portland Cement; 2015.
- J. ASTM C207 - Standard Specification for Hydrated Lime for Masonry Purposes; 2006 (Reapproved 2011).
- K. ASTM C270 - Standard Specification for Mortar for Unit Masonry; 2014a.
- L. ASTM C404 - Standard Specification for Aggregates for Masonry Grout; 2011.
- M. ASTM C476 - Standard Specification for Grout for Masonry; 2010.
- N. ASTM C780 - Standard Test Method for Preconstruction and Construction Evaluation of Mortars for Plain and Reinforced Unit Masonry; 2012.

**1.04 SUBMITTALS**

- A. See Section 01 30 00 - Administrative Requirements, for submittal procedures.
- B. Product Data: Provide data for masonry units, fabricated wire reinforcement, mortar, and masonry accessories.
- C. Manufacturer's Certificate: Certify that masonry units meet or exceed specified requirements.

**1.05 QUALITY ASSURANCE**

- A. Comply with provisions of ACI 530/530.1/ERTA, except where exceeded by requirements of the contract documents.

### **1.06 DELIVERY, STORAGE, AND HANDLING**

- A. Deliver, handle, and store masonry units by means that will prevent mechanical damage and contamination by other materials.

## **PART 2 PRODUCTS**

### **2.01 CONCRETE MASONRY UNITS**

- A. Concrete Block: Comply with referenced standards and as follows:
  - 1. Size: Standard units with nominal face dimensions of 16 by 8 inches and nominal depths as indicated on the drawings for specific locations.
  - 2. Special Shapes: Provide non-standard blocks configured for corners.
  - 3. Non-Loadbearing Units: ASTM C129.
    - a. Hollow block, as indicated.
    - b. Lightweight.

### **2.02 MORTAR AND GROUT MATERIALS**

- A. Portland Cement: ASTM C150/C150M, Type I.
  - 1. Not more than 0.60 percent alkali.
- B. Hydrated Lime: ASTM C207, Type S.
- C. Mortar Aggregate: ASTM C144.
- D. Grout Aggregate: ASTM C404.
- E. Water: Clean and potable.

### **2.03 REINFORCEMENT AND ANCHORAGE**

- A. Manufacturers:
  - 1. Blok-Lok Limited; \_\_\_\_\_: [www.blok-lok.com](http://www.blok-lok.com).
  - 2. Hohmann & Barnard, Inc; 2-Seal Tie: [www.h-b.com/sle](http://www.h-b.com/sle).
  - 3. WIRE-BOND: [www.wirebond.com](http://www.wirebond.com).
  - 4. Substitutions: See Section 01 60 00 - Product Requirements.
- B. Reinforcing Steel: ASTM A615/A615M, Grade 40 (40,000 psi), deformed billet bars; galvanized.
- C. Joint Reinforcement: Use ladder type joint reinforcement where vertical reinforcement is involved and truss type elsewhere, unless otherwise indicated.
- D. Single Wythe Joint Reinforcement: Truss or ladder type; ASTM A1064/A1064M steel wire, mill galvanized to ASTM A641/A641M, Class 3; 0.1483 inch side rods with 0.1483 inch cross rods; width as required to provide not more than 1 inch and not less than 1/2 inch of mortar coverage on each exposure.

### **2.04 ACCESSORIES**

- A. Cleaning Solution: Non-acidic, not harmful to masonry work or adjacent materials.

### **2.05 MORTAR AND GROUT MIXES**

- A. Mortar for Unit Masonry: ASTM C270, using the Proportion Specification.
- B. Grout: ASTM C476; consistency required to fill completely volumes indicated for grouting; fine grout for spaces with smallest horizontal dimension of 2 inches or less; coarse grout for spaces with smallest horizontal dimension greater than 2 inches.

## **PART 3 EXECUTION**

### **3.01 EXAMINATION**

- A. Verify that field conditions are acceptable and are ready to receive masonry.
- B. Verify that related items provided under other sections are properly sized and located.

- C. Verify that built-in items are in proper location, and ready for roughing into masonry work.

**3.02 PREPARATION**

- A. Direct and coordinate placement of metal anchors supplied for installation under other sections.
- B. Provide temporary bracing during installation of masonry work. Maintain in place until building structure provides permanent bracing.

**3.03 COLD AND HOT WEATHER REQUIREMENTS**

- A. Comply with requirements of ACI 530/530.1/ERTA or applicable building code, whichever is more stringent.

**3.04 COURSING**

- A. Establish lines, levels, and coursing indicated. Protect from displacement.
- B. Maintain masonry courses to uniform dimension. Form vertical and horizontal joints of uniform thickness.
- C. Concrete Masonry Units:
  - 1. Bond: Running.
  - 2. Coursing: One unit and one mortar joint to equal 8 inches.
  - 3. Mortar Joints: Flush.

**3.05 PLACING AND BONDING**

- A. Lay solid masonry units in full bed of mortar, with full head joints, uniformly jointed with other work.
- B. Lay hollow masonry units with face shell bedding on head and bed joints.
- C. Buttering corners of joints or excessive furrowing of mortar joints is not permitted.
- D. Remove excess mortar and mortar smears as work progresses.
- E. Remove excess mortar with water repellent admixture promptly. Do not use acids, sandblasting or high pressure cleaning methods.
- F. Interlock intersections and external corners, except for units laid in stack bond.
- G. Do not shift or tap masonry units after mortar has achieved initial set. Where adjustment must be made, remove mortar and replace.
- H. Perform job site cutting of masonry units with proper tools to provide straight, clean, unchipped edges. Prevent broken masonry unit corners or edges.
- I. Isolate masonry partitions from vertical structural framing members with a control joint as indicated.
- J. Isolate top joint of masonry partitions from horizontal structural framing members and slabs or decks with compressible joint filler.

**3.06 REINFORCEMENT AND ANCHORAGE - GENERAL**

- A. Unless otherwise indicated on drawings or specified under specific wall type, install horizontal joint reinforcement 16 inches on center.
- B. Place masonry joint reinforcement in first and second horizontal joints above and below openings. Extend minimum 16 inches each side of opening.
- C. Place continuous joint reinforcement in first and second joint below top of walls.
- D. Lap joint reinforcement ends minimum 6 inches.

**3.07 LINTELS**

- A. Install loose steel lintels over openings.

### **3.08 BUILT-IN WORK**

- A. As work progresses, install built-in metal door frames and other items to be built into the work and furnished under other sections.
- B. Install built-in items plumb, level, and true to line.
- C. Bed anchors of metal door and glazed frames in adjacent mortar joints. Fill frame voids solid with grout.
- D. Do not build into masonry construction organic materials that are subject to deterioration.

### **3.09 TOLERANCES**

- A. Maximum Variation From Unit to Adjacent Unit: 1/16 inch.
- B. Maximum Variation from Plane of Wall: 1/4 inch in 10 ft and 1/2 inch in 20 ft or more.
- C. Maximum Variation from Plumb: 1/4 inch per story non-cumulative; 1/2 inch in two stories or more.
- D. Maximum Variation from Level Coursing: 1/8 inch in 3 ft and 1/4 inch in 10 ft; 1/2 inch in 30 ft.
- E. Maximum Variation of Mortar Joint Thickness: Head joint, minus 1/4 inch, plus 3/8 inch.
- F. Maximum Variation from Cross Sectional Thickness of Walls: 1/4 inch.

### **3.10 CUTTING AND FITTING**

- A. Cut and fit for pipes, conduit, sleeves, and grounds. Coordinate with other sections of work to provide correct size, shape, and location.
- B. Obtain approval prior to cutting or fitting masonry work not indicated or where appearance or strength of masonry work may be impaired.

### **3.11 FIELD QUALITY CONTROL**

- A. An independent testing agency will perform field quality control tests, as specified in Section 01 40 00 - Quality Requirements.
- B. Concrete Masonry Unit Tests: Test each variety of concrete unit masonry in accordance with ASTM C140/C140M for conformance to requirements of this specification.
- C. Mortar Tests: Test each type of mortar in accordance with ASTM C780, testing with same frequency as masonry samples.

### **3.12 CLEANING**

- A. Remove excess mortar and mortar droppings.
- B. Replace defective mortar. Match adjacent work.
- C. Clean soiled surfaces with cleaning solution.

**END OF SECTION**

**SECTION 07 84 00**  
**FIRESTOPPING**

**PART 1 GENERAL**

**1.01 SECTION INCLUDES**

- A. Firestopping systems.

**1.02 RELATED REQUIREMENTS**

**1.03 REFERENCE STANDARDS**

- A. ASTM E119 - Standard Test Methods for Fire Tests of Building Construction and Materials; 2015.
- B. ASTM E814 - Standard Test Method for Fire Tests of Through-Penetration Fire Stops; 2013a.
- C. ITS (DIR) - Directory of Listed Products; current edition.
- D. FM 4991 - Approval Standard for Firestop Contractors; 2013.
- E. FA (AG) - FM Approval Guide; Factory Mutual Research Corporation; current edition.
- F. UL (FRD) - Fire Resistance Directory; current edition.

**1.04 SUBMITTALS**

- A. See Section 01 30 00 - Administrative Requirements, for submittal procedures.
- B. Product Data: Provide data on product characteristics, performance ratings, and limitations.

**1.05 QUALITY ASSURANCE**

- A. Fire Testing: Provide firestopping assemblies of designs that provide the scheduled fire ratings when tested in accordance with methods indicated.
  - 1. Listing in the current-year classification or certification books of UL, FM, or ITS (Warnock Hersey) will be considered as constituting an acceptable test report.
  - 2. Valid evaluation report published by ICC Evaluation Service, Inc. (ICC-ES) at [www.icc-es.org](http://www.icc-es.org) will be considered as constituting an acceptable test report.
  - 3. Submission of actual test reports is required for assemblies for which none of the above substantiation exists.
- B. Manufacturer Qualifications: Company specializing in manufacturing the products specified in this section with minimum three years documented experience.
- C. Installer Qualifications: Company specializing in performing the work of this section and:
  - 1. Approved by Factory Mutual Research Corporation under FM 4991, or meeting any two of the following requirements:.
  - 2. With minimum 3 years documented experience installing work of this type.
  - 3. Able to show at least 5 satisfactorily completed projects of comparable size and type.

**1.06 FIELD CONDITIONS**

- A. Comply with firestopping manufacturer's recommendations for temperature and conditions during and after installation. Maintain minimum temperature before, during, and for 3 days after installation of materials.
- B. Provide ventilation in areas where solvent-cured materials are being installed.

**PART 2 PRODUCTS**

**2.01 FIRESTOPPING - GENERAL REQUIREMENTS**

- A. Primers, Sleeves, Forms, Insulation, Packing, Stuffing, and Accessories: Type required for tested assembly design.



## 2.02 FIRESTOPPING SYSTEMS

- A. Firestopping at Uninsulated Metallic Pipe and Conduit Penetrations, of diameter 4 inches or less: Caulk or putty.
  - 1. Floors: ULUL Design No. F-A-1046, F Rating 2 hour.
  - 2. 2-hour fire barriers and shaft walls: UL Design No. W-L-1146, F Rating 2 hour.
  - 3. 1-hour fire barriers and shaft walls: ULUL Design No. W-L-1146, F Rating 1 hour.
  - 4. 0-hour fire barriers and shaft walls: UL Design No. W-L-1146, T Rating 0 hour.
- B. Firestopping at Combustible Pipe and Conduit Penetrations, of diameter 4 inches or less: Intumescent elastomeric wrap strip with aluminum facing.
  - 1. Floors: ULUL Design No. F-A-2110, F Rating 2 hour.
  - 2. 2-hour fire barriers and shaft walls: ULUL Design No. W-L-2003, F Rating 2 hour.
  - 3. 1-hour fire barriers and shaft walls: ULUL Design No. W-L-2003, F Rating 1 hour.
  - 4. 0-hour fire barriers and shaft walls: UL Design No. W-L-2003, T Rating 0 hour.
- C. Firestopping at Openings with No Penetrating Items: Pillows with caulk or putty.
  - 1. 2-hour fire barriers and shaft walls: ULUL Design No. W-L-0011, F Rating 2 hour.
  - 2. 2-hour fire barriers and shaft walls: ULUL Design No. W-L-0011, F Rating 1 hour.
- D. Firestopping at Cable Penetrations, not in Conduit or Cable Tray: Intumescent elastomeric wrap strip with aluminum facing and caulk or putty.
  - 1. 2-hour fire barriers and shaft walls: ULUL Design No. W-L-3030, F Rating 2 hour.
  - 2. 1-hour fire barriers and shaft walls: ULUL Design No. W-L-3030, F Rating 1 hour.
- E. Firestopping at Penetrations with Insulated Metallic Pipe: Intumescent elastomeric wrap strip with aluminum facing and caulk or putty.
  - 1. Floors: UL Design No. F-A-5029, F Rating 2 hour.
  - 2. 2-hour fire barriers and shaft walls: UL Design No. W-L-5001, F Rating 2 hour.
  - 3. 1-hour fire barriers and shaft walls: UL Design No. W-L-5001, F Rating 1 hour.
  - 4. [1/2-hour fire barriers and shaft walls]: UL Design No. [W-L-5001], T Rating 1/2 hour.
- F. Firestopping at Penetrations with Rectangular Steel Duct: Packing material with sealant or caulk.
  - 1. 2-hour fire barriers and shaft walls: UL Design No. W-L-5001, F Rating 2 hour.
  - 2. 1-hour fire barriers and shaft walls: UL Design No. W-L-5001, F Rating 1 hour.
- G. Firestopping Between Edge of Floor Slab and Curtain Wall (without Penetrations): Fiber firestopping with smoke seal coating; UL Design No. \_\_\_\_\_, T Rating 3/4 hour.
- H. Firestopping Between Top of Partition Wall and Floor Slab: Fiber firestopping with smoke seal coating; UL Design No. HWD-0020, Assembly Rating: 2 hour.

## PART 3 EXECUTION

### 3.01 EXAMINATION

- A. Verify openings are ready to receive the work of this section.

### 3.02 PREPARATION

- A. Clean substrate surfaces of dirt, dust, grease, oil, loose material, or other matter that could adversely affect bond of firestopping material.
- B. Remove incompatible materials that could adversely affect bond.

### 3.03 INSTALLATION

- A. Install materials in manner described in fire test report and in accordance with manufacturer's instructions, completely closing openings.
- B. Do not cover installed firestopping until inspected by authorities having jurisdiction.
- C. Install labeling required by code.

**3.04 CLEANING**

- A. Clean adjacent surfaces of firestopping materials.

**3.05 PROTECTION**

- A. Protect adjacent surfaces from damage by material installation.

**END OF SECTION**

**SECTION 07 92 00**  
**JOINT SEALANTS**

**PART 2 PRODUCTS**

**1.01 JOINT SEALANT APPLICATIONS**

- A. Scope:
1. Exterior Joints: Seal open joints, whether or not the joint is indicated on the drawings, unless specifically indicated not to be sealed. Exterior joints to be sealed include, but are not limited to, the following items.
    - a. Wall expansion and control joints.
    - b. Joints between door, window, and other frames and adjacent construction.
    - c. Joints between different exposed materials.
    - d. Openings below ledge angles in masonry.
    - e. Other joints indicated below.
  2. Interior Joints: Do not seal interior joints unless specifically indicated to be sealed. Interior joints to be sealed include, but are not limited to, the following items.
    - a. Joints between door, window, and other frames and adjacent construction.
    - b. Other joints indicated below.
  3. Do not seal the following types of joints.
    - a. Intentional weepholes in masonry.
    - b. Joints indicated to be treated with manufactured expansion joint cover or some other type of sealing device.
    - c. Joints where sealant is specified to be provided by manufacturer of product to be sealed.
    - d. Joints where installation of sealant is specified in another section.
    - e. Joints between suspended panel ceilings/grid and walls.
- B. Exterior Joints: Use non-sag non-staining silicone sealant, Type \_\_\_\_\_, unless otherwise indicated.
- C. Interior Joints: Use non-sag polyurethane sealant, Type \_\_\_\_\_, unless otherwise indicated.
1. Wall and Ceiling Joints in Non-Wet Areas: Acrylic emulsion latex sealant; Type \_\_\_\_\_.

**1.02 JOINT SEALANTS - GENERAL**

**1.03 NONSAG JOINT SEALANTS**

- A. Type \_\_\_\_ - Non-Staining Silicone Sealant: ASTM C920, Grade NS, Uses M and A; not expected to withstand continuous water immersion or traffic.
1. Movement Capability: Plus and minus 50 percent, minimum.
  2. Non-Staining To Porous Stone: Non-staining to light-colored natural stone when tested in accordance with ASTM C1248.
  3. Dirt Pick-Up: Reduced dirt pick-up compared to other silicone sealants.
- B. Type \_\_\_\_ - Polyurethane Sealant: ASTM C920, Grade NS, Uses M and A; single or multi-component; not expected to withstand continuous water immersion or traffic.
1. Movement Capability: Plus and minus 25 percent, minimum.
- C. Type \_\_\_\_ - Acrylic Emulsion Latex: Water-based; ASTM C834, single component, non-staining, non-bleeding, non-sagging; not intended for exterior use.

**1.04 ACCESSORIES**

- A. Backer Rod: Cylindrical cellular foam rod with surface that sealant will not adhere to, compatible with specific sealant used, and recommended by backing and sealant manufacturers for specific application.

**END OF SECTION**

THE UNIVERSITY OF TEXAS HEALTH SCIENCE CENTER  
UCT Equipment Replacement  
Shah Smith & Associates, Inc.  
1095-027-01

JOINT SEALANTS  
07 92 00 - 2

**SECTION 08 11 13**  
**HOLLOW METAL DOORS AND FRAMES**

**PART 1 GENERAL**

**1.01 SECTION INCLUDES**

- A. Non-fire-rated hollow metal doors and frames.
- B. Fire-rated hollow metal doors and frames.
- C. Thermally insulated hollow metal doors with frames.

**1.02 RELATED REQUIREMENTS**

- A. Section 08 71 00 - Door Hardware.
- B. Section 09 91 13 - Exterior Painting: Field painting.

**1.03 REFERENCE STANDARDS**

- A. ADA Standards - Americans with Disabilities Act (ADA) Standards for Accessible Design; 2010.
- B. ANSI/SDI A250.3 - Test Procedure and Acceptance Criteria for Factory Applied Finish Coatings for Steel Doors and Frames; 2007 (R2011).
- C. ANSI/SDI A250.4 - Test Procedure and Acceptance Criteria for Physical Endurance for Steel Doors, Frames and Frame Anchors; 2011.
- D. ANSI/SDI A250.8 - Specifications for Standard Steel Doors and Frames (SDI-100); 2014.
- E. ANSI/SDI A250.10 - Test Procedure and Acceptance Criteria for Prime Painted Steel Surfaces for Steel Doors and Frames; 2011.
- F. ASTM A653/A653M - Standard Specification for Steel Sheet, Zinc-Coated (Galvanized) or Zinc-Iron Alloy-Coated (Galvannealed) by the Hot-Dip Process; 2015.
- G. ASTM A1008/A1008M - Standard Specification for Steel, Sheet, Cold-Rolled, Carbon, Structural, High-Strength Low-Alloy, High-Strength Low-Alloy with Improved Formability, Solution Hardened, and Bake Hardenable; 2015.
- H. ASTM A1011/A1011M - Standard Specification for Steel, Sheet and Strip, Hot-Rolled, Carbon, Structural, High-Strength Low-Alloy, High-Strength Low-Alloy with Improved Formability, and Ultra-High Strength; 2014.
- I. ICC A117.1 - Accessible and Usable Buildings and Facilities; 2009.
- J. ITS (DIR) - Directory of Listed Products; current edition.
- K. NAAMM HMMA 840 - Guide Specifications for Installation and Storage of Hollow Metal Doors and Frames; 2007.
- L. NFPA 80 - Standard for Fire Doors and Other Opening Protectives; 2016.
- M. NFPA 252 - Standard Methods of Fire Tests of Door Assemblies; 2012.
- N. UL (BMD) - Building Materials Directory; current edition.
- O. UL (DIR) - Online Certifications Directory; current listings at database.ul.com.
- P. UL 10C - Standard for Positive Pressure Fire Tests of Door Assemblies; Current Edition, Including All Revisions.

**1.04 SUBMITTALS**

- A. See Section 01 30 00 - Administrative Requirements, for submittal procedures.
- B. Product Data: Materials and details of design and construction, hardware locations, reinforcement type and locations, anchorage and fastening methods, and finishes; and one copy of referenced standards/guidelines.

- C. Shop Drawings: Details of each opening, showing elevations, glazing, frame profiles, and any indicated finish requirements.

#### **1.05 DELIVERY, STORAGE, AND HANDLING**

- A. Comply with NAAMM HMMA 840 or ANSI/SDI A250.8 (SDI-100) in accordance with specified requirements.
- B. Protect with resilient packaging; avoid humidity build-up under coverings; prevent corrosion and adverse effects on factory applied painted finish.

### **PART 2 PRODUCTS**

#### **2.01 MANUFACTURERS**

- A. Hollow Metal Doors and Frames:
  - 1. Ceco Door, an Assa Abloy Group company; \_\_\_\_\_: [www.assaabloydss.com](http://www.assaabloydss.com).
  - 2. De La Fontaine Inc; Hollow Metal Door Model \_\_\_\_\_: [www.delafontaine.com](http://www.delafontaine.com).
  - 3. De La Fontaine Inc; Windstorm-Resistant Steel Door and Frame; door style \_\_\_\_: [www.delafontaine.com](http://www.delafontaine.com).
  - 4. De La Fontaine Inc; Hollow Metal Frame \_\_\_\_ Profile: [www.delafontaine.com](http://www.delafontaine.com).
  - 5. Republic Doors; \_\_\_\_\_: [www.republicdoor.com](http://www.republicdoor.com).
  - 6. Steelcraft, an Allegion brand; \_\_\_\_\_: [www.allegion.com/sle](http://www.allegion.com/sle).
  - 7. Technical Glass Products; SteelBuilt Window & Door Systems: [www.tgpamerica.com](http://www.tgpamerica.com).
  - 8. Substitutions: See Section 01 60 00 - Product Requirements.

#### **2.02 DESIGN CRITERIA**

- A. Requirements for Hollow Metal Doors and Frames:
  - 1. Steel used for fabrication of doors and frames shall comply with one or more of the following requirements; Galvannealed steel conforming to ASTM A653/A653M, cold-rolled steel conforming to ASTM A1008/A1008M, or hot-rolled pickled and oiled (HRPO) steel conforming to ASTM A1011/A1011M, Commercial Steel (CS) Type B for each.
  - 2. Accessibility: Comply with ICC A117.1 and ADA Standards.
  - 3. Exterior Door Top Closures: Flush end closure channel, with top and door faces aligned.
- B. Combined Requirements: If a particular door and frame unit is indicated to comply with more than one type of requirement, comply with the specified requirements for each type; for instance, an exterior door that is also indicated as being sound-rated must comply with the requirements specified for exterior doors and for sound-rated doors; where two requirements conflict, comply with the most stringent.

#### **2.03 HOLLOW METAL DOORS**

- A. Type \_\_\_\_, Fire-Rated Doors:
  - 1. Based on SDI Standards: ANSI/SDI A250.8 (SDI-100).
    - a. Level 1 - Standard-duty.
    - b. Physical Performance Level C, 250,000 cycles; in accordance with ANSI/SDI A250.4.
    - c. Model 1 - Full Flush.
    - d. Door Face Metal Thickness: 20 gage, 0.032 inch, minimum.
  - 2. Fire Rating: As indicated on Door Schedule, tested in accordance with UL 10C and NFPA 252 ("positive pressure fire tests").
  - 3. Provide units listed and labeled by UL (DIR) or ITS (DIR).
    - a. Attach fire rating label to each fire rated unit.
  - 4. Door Thickness: 1-3/4 inch, nominal.

#### **2.04 HOLLOW METAL FRAMES**

- A. Comply with standards and/or custom guidelines as indicated for corresponding door in accordance with applicable door frame requirements.

- B. Frame Finish: Factory finished.
- C. Exterior Door Frames: Knock-down type.
  - 1. Galvanizing: Components hot-dipped zinc-iron alloy-coated (galvannealed) in accordance with ASTM A653/A653M, with A40/ZF120 coating.
  - 2. Frame Metal Thickness: 18 gage, 0.042 inch, minimum.
  - 3. Weatherstripping: Separate, see Section 08 71 00.
- D. Door Frames, Fire-Rated: Knock-down type.
  - 1. Fire Rating: Same as door, labeled.
  - 2. Frame Metal Thickness: 18 gage, 0.042 inch, minimum.
- E. Provide mortar guard boxes for hardware cut-outs in frames to be installed in masonry or to be grouted.
- F. Frames in Masonry Walls: Size to suit masonry coursing with head member 4 inch high to fill opening without cutting masonry units.
- G. Frames Wider than 48 Inch: Reinforce with steel channel fitted tightly into frame head, flush with top.

## **2.05 ACCESSORIES**

- A. Grout for Frames: Portland cement grout with maximum 4 inch slump for hand troweling; thinner pumpable grout is prohibited.
- B. Silencers: Resilient rubber, fitted into drilled hole; 3 on strike side of single door, 3 on center mullion of pairs, and 2 on head of pairs without center mullions.
- C. Temporary Frame Spreaders: Provide for factory- or shop-assembled frames.

## **2.06 FINISHES**

- A. Primer: Rust-inhibiting, complying with ANSI/SDI A250.10, door manufacturer's standard.
- B. Factory Finish: Complying with ANSI/SDI A250.3, manufacturer's standard coating.
- C. Bituminous Coating: Asphalt emulsion or other high-build, water-resistant, resilient coating.

## **PART 3 EXECUTION**

### **3.01 EXAMINATION**

- A. Verify existing conditions before starting work.
- B. Verify that opening sizes and tolerances are acceptable.
- C. Verify that finished walls are in plane to ensure proper door alignment.

### **3.02 PREPARATION**

- A. Coat inside of frames to be installed in masonry or to be grouted, with bituminous coating, prior to installation.

### **3.03 INSTALLATION**

- A. Install doors and frames in accordance with manufacturer's instructions and related requirements of specified door and frame standards or custom guidelines indicated.
- B. Install fire rated units in accordance with NFPA 80.
- C. Coordinate frame anchor placement with wall construction.
- D. Grout frames in masonry construction, using hand trowel methods; brace frames so that pressure of grout before setting will not deform frames.
- E. Coordinate installation of hardware.
- F. Touch up damaged factory finishes.

**3.04 TOLERANCES**

- A. Maximum Diagonal Distortion: 1/16 in measured with straight edge, corner to corner.

**3.05 ADJUSTING**

- A. Adjust for smooth and balanced door movement.

**END OF SECTION**



**SECTION 08 71 00**  
**DOOR HARDWARE**

**PART 1 GENERAL**

**1.01 SECTION INCLUDES**

- A. Hardware for hollow metal doors.
- B. Hardware for fire-rated doors.
- C. Electrically operated and controlled hardware.
- D. Thresholds.
- E. Weatherstripping, seals and door gaskets.

**1.02 RELATED REQUIREMENTS**

- A. Section 08 11 13 - Hollow Metal Doors and Frames.

**1.03 REFERENCE STANDARDS**

- A. 36 CFR 1191 - Americans with Disabilities Act (ADA) Accessibility Guidelines for Buildings and Facilities; Architectural Barriers Act (ABA) Accessibility Guidelines; current edition.
- B. ADA Standards - Americans with Disabilities Act (ADA) Standards for Accessible Design; 2010.
- C. BHMA A156.2 - American National Standard for Bored and Preassembled Locks & Latches; 2011.
- D. BHMA A156.4 - American National Standard for Door Controls - Closers; 2013.
- E. BHMA A156.6 - American National Standard for Architectural Door Trim; 2010.
- F. BHMA A156.17 - American National Standard for Self Closing Hinges & Pivots; 2014.
- G. BHMA A156.18 - American National Standard for Materials and Finishes; 2012.
- H. BHMA A156.21 - American National Standard for Thresholds; 2014.
- I. BHMA A156.22 - American National Standard for Door Gasketing and Edge Seal Systems, Builders Hardware Manufacturers Association; 2012.
- J. BHMA A156.115 - American National Standard for Hardware Preparation in Steel Doors and Steel Frames; 2014.
- K. DHI (LOCS) - Recommended Locations for Architectural Hardware for Standard Steel Doors and Frames; 2004.
- L. ICC A117.1 - Accessible and Usable Buildings and Facilities; 2009.
- M. NFPA 80 - Standard for Fire Doors and Other Opening Protectives; 2016.
- N. NFPA 101 - Life Safety Code; 2015.
- O. UL (DIR) - Online Certifications Directory; current listings at [database.ul.com](http://database.ul.com).

**1.04 ADMINISTRATIVE REQUIREMENTS**

- A. Coordinate the manufacture, fabrication, and installation of products that door hardware will be installed upon.
- B. Furnish templates for door and frame preparation to manufacturers and fabricators of products requiring internal reinforcement for door hardware.
- C. Convey Owner's keying requirements to manufacturers.

**1.05 SUBMITTALS**

- A. See Section 01 30 00 - Administrative Requirements, for submittal procedures.

- B. Product Data: Manufacturer's catalog literature for each type of hardware, marked to clearly show products to be furnished for this project.
- C. Hardware Schedule: Detailed listing of each item of hardware to be installed on each door. Use door numbering scheme as included in the Contract Documents. Identify electrically operated items and include power requirements.
- D. Keying Schedule: Submit for approval of Owner.
- E. Manufacturer's Installation Instructions: Indicate special procedures, perimeter conditions requiring special attention.
- F. Maintenance Data: Include data on operating hardware, lubrication requirements, and inspection procedures related to preventative maintenance.
  - 1. Submit manufacturer's parts lists and templates.
  - 2. Bitting List: List of combinations as furnished.
- G. Keys: Deliver with identifying tags to Owner by security shipment direct from hardware supplier.
- H. Warranty: Submit manufacturer's warranty and ensure that forms have been completed in Owner's name and registered with manufacturer.
- I. Project Record Documents: Record actual locations of concealed equipment, services, and conduit.
- J. Maintenance Materials and Tools: Furnish the following for Owner's use in maintenance of project.
  - 1. See Section 01 60 00 - Product Requirements, for additional provisions.
  - 2. Tools: One set of all special wrenches or tools applicable to each different or special hardware component, whether supplied by the hardware component manufacturer or not.

#### **1.06 QUALITY ASSURANCE**

- A. Standards for Fire-Rated Doors: Maintain one copy of each referenced standard on site, for use by Architect and Contractor.
- B. Manufacturer Qualifications: Company specializing in manufacturing the products specified in this section with minimum three years of documented experience.
- C. Hardware Supplier Personnel: Employ an Architectural Hardware Consultant (AHC) to assist in the work of this section.

#### **1.07 DELIVERY, STORAGE, AND HANDLING**

- A. Package hardware items individually; label and identify each package with door opening code to match hardware schedule.

#### **1.08 WARRANTY**

- A. See Section 01 78 00 - Closeout Submittals, for additional warranty requirements.
- B. Provide five year warranty for door closers.

### **PART 2 PRODUCTS**

#### **2.01 MANUFACTURERS - BASIS OF DESIGN**

- A. Basis of Design: Best Access Systems, division of Stanley Security Solutions: [www.bestaccess.com](http://www.bestaccess.com).
- B. Substitutions: No substitutions allowed.

#### **2.02 DOOR HARDWARE - GENERAL**

- A. Provide hardware specified or required to make doors fully functional, compliant with applicable codes, and secure to the extent indicated.
- B. Provide items of a single type of the same model by the same manufacturer.

- C. Provide products that comply with the following:
  - 1. Applicable provisions of federal, state, and local codes.
  - 2. Accessibility: ADA Standards and ICC A117.1.
  - 3. Applicable provisions of NFPA 101, Life Safety Code.
  - 4. Fire-Rated Doors: NFPA 80.
  - 5. Hardware on Fire-Rated Doors, Except Hinges: Listed and classified by UL (DIR) as suitable for the purpose specified and indicated.
  - 6. Hardware Preparation for Steel Doors and Steel Frames: BHMA A156.115.
  - 7. Hardware for Smoke and Draft Control Doors (Indicated as "S" on Drawings): Provide hardware that enables door assembly to comply with air leakage requirements of the applicable code.
  - 8. Products Requiring Electrical Connection: Listed and classified by UL (DIR) as suitable for the purpose specified and indicated.
- D. Function: Lock and latch function numbers and descriptions of manufactures series as listed in hardware schedule.
- E. Electrically Operated and/or Controlled Hardware: Provide all power supplies, power transfer hinges, relays, and interfaces required for proper operation; provide wiring between hardware and control components and to building power connection.
- F. Finishes: Provide door hardware of the same finish unless otherwise indicated.
  - 1. Primary Finish: Satin chrome plated over nickel on brass or bronze, 626 (approx US26D).
  - 2. Secondary Finish: Satin chrome plated over nickel on brass or bronze, 626 (approx US26D).
  - 3. Finish Definitions: BHMA A156.18.
  - 4. Exceptions:
    - a. Where base metal is specified to be different, provide finish that is an appearance equivalent according to BHMA A156.18.
    - b. Hinges for Fire-Rated Doors: Steel base metal with painted finish.

### **2.03 LOCKS AND LATCHES**

- A. Locks: Provide a lock for every door, unless specifically indicated as not requiring locking.
  - 1. If no hardware set is indicated for a swinging door provide an office lockset.
  - 2. Trim: Provide lever handle or pull trim on outside of all locks unless specifically stated to have no outside trim.
  - 3. Lock Cylinders: Provide key access on outside of all locks unless specifically stated to have no locking or no outside trim.
- B. Lock Cylinders: Manufacturer's standard tumbler type, six-pin standard core.
  - 1. Provide cams and/or tailpieces as required for locking devices required.
- C. Keying: Grand master keyed.
- D. Latches: Provide a latch for every door that is not required to lock, unless specifically indicated "push/pull" or "not required to latch".

### **2.04 HINGES**

- A. Hinges: Provide hinges on every swinging door.
  - 1. Provide five-knuckle full mortise butt hinges unless otherwise indicated.
  - 2. Provide ball-bearing hinges at all doors having closers.
  - 3. Provide hinges in the quantities indicated.
  - 4. Provide non-removable pins on exterior outswinging doors.
- B. Quantity of Hinges Per Door:
  - 1. Doors From 60 inches High up to 90 inches High: Three hinges.

## **2.05 PIVOTS**

- A. Pivots: Comply with BHMA A156.17.

## **2.06 PUSH/PULLS**

- A. Push/Pulls: Comply with BHMA A156.6.
  - 1. Provide push and pull on doors not specified to have lockset, latchset, exit device, or auxiliary lock.
  - 2. On solid doors, provide matching push plate and pull plate on opposite faces.

## **2.07 CYLINDRICAL LOCKSETS**

- A. Locking Functions: As defined in BHMA A156.2, and as follows.
  - 1. Always-Locked: F86, key required to lock, may not be left unlocked.

## **2.08 FLUSHBOLTS AND COORDINATORS**

- A. Self-Latching Flushbolts: Automatically latch upon closing of door; manually retracted.
- B. Automatic Flushbolts: Automatically latch upon closing of door; automatic retraction of bolts when active leaf is opened.

## **2.09 EXIT DEVICES**

## **2.10 CLOSERS**

- A. Closers: Complying with BHMA A156.4.
  - 1. Provide surface-mounted, door-mounted closers unless otherwise indicated.
  - 2. Provide a door closer on every exterior door.
  - 3. Provide a door closer on every fire- and smoke-rated door. Spring hinges are not an acceptable self-closing device unless specifically so indicated.
  - 4. On pairs of swinging doors, if an overlapping astragal is present, provide coordinator to ensure the leaves close in proper order.
  - 5. At outswinging exterior doors, mount closer in inside of door.

## **2.11 GASKETING AND THRESHOLDS**

- A. Gaskets: Complying with BHMA A156.22.
  - 1. On each door in smoke partition, provide smoke gaskets; top, sides, and meeting stile of pairs. If fire/smoke partitions are not indicated on drawings, provide smoke gaskets on each door identified as a "smoke door" and 20-minute rated fire doors.
  - 2. On each exterior door, provide weatherstripping gaskets, unless otherwise indicated; top, sides, and meeting stiles of pairs.
    - a. Where exterior door is also required to have fire or smoke rating, provide gaskets functioning as both smoke and weather seals.
  - 3. On each exterior door, provide door bottom sweep, unless otherwise indicated.
- B. Thresholds: Complying with BHMA A156.21.
  - 1. At each exterior door, provide a threshold unless otherwise indicated.

## **PART 3 EXECUTION**

### **3.01 EXAMINATION**

- A. Verify that doors and frames are ready to receive work; labeled, fire-rated doors and frames are present and properly installed, and dimensions are as indicated on shop drawings.
- B. Verify that electric power is available to power operated devices and of the correct characteristics.

### **3.02 INSTALLATION**

- A. Install hardware in accordance with manufacturer's instructions and applicable codes.
- B. Use templates provided by hardware item manufacturer.

- C. Install hardware on fire-rated doors and frames in accordance with code and NFPA 80.
- D. Mounting heights for hardware from finished floor to center line of hardware item.
  - 1. For steel doors and frames: Comply with DHI "Recommended Locations for Architectural Hardware for Steel Doors and Frames."
  - 2. For Steel Doors and Frames: Refer to Section 08 11 13.
- E. Set exterior door thresholds with full-width bead of elastomeric sealant on each point of contact with floor providing a continuous weather seal; anchor thresholds with stainless steel countersunk screws.

### **3.03 ADJUSTING**

- A. Adjust work under provisions of Section 01 70 00.
- B. Adjust hardware for smooth operation.

### **3.04 CLEANING**

- A. Clean adjacent surfaces soiled by hardware installation. Clean finished hardware per manufacturer's instructions after final adjustments has been made. Replace items that cannot be cleaned to manufacturer's level of finish quality at no additional cost.

### **3.05 PROTECTION**

- A. Protect finished Work under provisions of Section 01 70 00.
- B. Do not permit adjacent work to damage hardware or finish.

### **3.06 SCHEDULE - ATTACHED**

#### **HARDWARE SETS**

#### **4.01 HARDWARE SETS - GENERAL**

- A. These Hardware Sets indicate requirements for single doors of that type, with conditional requirements for pairs and other situations.
- B. Pairs of Swinging Doors: Provide one of each specified item on each leaf unless specifically stated otherwise. Treat pairs as two active leaves unless otherwise indicated.

#### **4.02 SWING DOORS -- MAY NOT BE LEFT UNLOCKED**

- A. HW-30F: Always-Locked, Fire-Rated and Non-Fire-Rated where Closer is Desired:
  - 1. Closer.
  - 2. Lockset, Always-Locked.
  - 3. Exit Device, Rim, Always-Locked
  - 4. Pair: One leaf inactive; automatic or self-closing flush bolts as required to comply with code. If door fire rating requires astragal, provide coordinator.

**END OF SECTION**

**SECTION 09 21 16**  
**GYPSUM BOARD ASSEMBLIES**

**PART 1 GENERAL**

**1.01 SECTION INCLUDES**

- A. Performance criteria for gypsum board assemblies.
- B. Metal stud wall framing.
- C. Metal channel ceiling framing.
- D. Acoustic insulation.
- E. Cementitious backing board.
- F. Gypsum wallboard.
- G. Joint treatment and accessories.
- H. Textured finish system.

**1.02 RELATED REQUIREMENTS**

- A. Section 01 61 16 - Volatile Organic Compound (VOC) Content Restrictions.
- B. Section 05 40 00 - Cold-Formed Metal Framing: Exterior wind-load-bearing metal stud framing.
- C. Section 06 10 00 - Rough Carpentry: Building framing and sheathing.
- D. Section 06 10 00 - Rough Carpentry: Wood blocking product and execution requirements.
- E. Section 07 21 00 - Thermal Insulation: Acoustic insulation.
- F. Section 07 25 00 - Weather Barriers: Water-resistive barrier over sheathing.
- G. Section 07 84 00 - Firestopping: Top-of-wall assemblies at fire rated walls.

**1.03 REFERENCE STANDARDS**

- A. AISI S100-12 - North American Specification for the Design of Cold-Formed Steel Structural Members; American Iron and Steel Institute; 2012.
- B. ANSI A108.11 - American National Standard for Interior Installation of Cementitious Backer Units; 2010 (Revised).
- C. ANSI A118.9 - American National Standard Specifications for Test Methods and Specifications for Cementitious Backer Units; 1999 (Reaffirmed 2010).
- D. ASTM A653/A653M - Standard Specification for Steel Sheet, Zinc-Coated (Galvanized) or Zinc-Iron Alloy-Coated (Galvannealed) by the Hot-Dip Process; 2015.
- E. ASTM C475/C475M - Standard Specification for Joint Compound and Joint Tape for Finishing Gypsum Board; 2015.
- F. ASTM C645 - Standard Specification for Nonstructural Steel Framing Members; 2014.
- G. ASTM C665 - Standard Specification for Mineral-Fiber Blanket Thermal Insulation for Light Frame Construction and Manufactured Housing; 2012.
- H. ASTM C754 - Standard Specification for Installation of Steel Framing Members to Receive Screw-Attached Gypsum Panel Products; 2015.
- I. ASTM C840 - Standard Specification for Application and Finishing of Gypsum Board; 2013.
- J. ASTM C954 - Standard Specification for Steel Drill Screws for the Application of Gypsum Panel Products or Metal Plaster Bases to Steel Studs From 0.033 in. (0.84 mm) to 0.112 in. (2.84 mm) in Thickness; 2015.
- K. ASTM C1002 - Standard Specification for Steel Self-Piercing Tapping Screws for Application of Gypsum Panel Products or Metal Plaster Bases to Wood Studs or Steel Studs; 2014.

- L. ASTM C1178/C1178M - Standard Specification for Coated Glass Mat Water-Resistant Gypsum Backing Panel; 2013.
- M. ASTM C1278/C1278M - Standard Specification for Fiber-Reinforced Gypsum Panel; 2007a (Reapproved 2011).
- N. ASTM C1288 - Standard Specification for Discrete Non-Asbestos Fiber-Cement Interior Substrate Sheets; 2014.
- O. ASTM C1325 - Specification for Non-Asbestos Fiber-Mat Reinforced Cementitious Backer Units; 2014.
- P. ASTM C1396/C1396M - Standard Specification for Gypsum Board; 2014.
- Q. ASTM C1658/C1658M - Standard Specification for Glass Mat Gypsum Panels; 2013.
- R. ASTM D3273 - Standard Test Method for Resistance to Growth of Mold on the Surface of Interior Coatings in an Environmental Chamber; 2012.
- S. ASTM E90 - Standard Test Method for Laboratory Measurement of Airborne Sound Transmission Loss of Building Partitions and Elements; 2009.
- T. ASTM E413 - Classification for Rating Sound Insulation; 2010.
- U. GA-216 - Application and Finishing of Gypsum Board; 2013.
- V. GA-226 - Application of Gypsum Board to Form Curved Surfaces; Gypsum Association; 2008.
- W. GA-600 - Fire Resistance Design Manual; 2015.
- X. ICC (IBC) - International Building Code; 2015.
- Y. UL (FRD) - Fire Resistance Directory; current edition.

#### **1.04 SUBMITTALS**

- A. See Section 01 30 00 - Administrative Requirements, for submittal procedures.
- B. Product Data: Provide data on metal framing, gypsum board, glass mat faced gypsum board, accessories, and joint finishing system.
- C. Product Data: Provide manufacturer's data on partition head to structure connectors, showing compliance with requirements.
- D. Test Reports: For stud framing products that do not comply with ASTM C645 or ASTM C754, provide independent laboratory reports showing maximum stud heights at required spacings and deflections.
- E. Samples: Submit two samples of gypsum board finished with proposed texture application, 12 by 12 inches in size, illustrating finish color and texture.

#### **1.05 QUALITY ASSURANCE**

- A. Installer Qualifications: Company specializing in performing gypsum board installation and finishing, with minimum three years of documented experience.

### **PART 2 PRODUCTS**

#### **2.01 GYPSUM BOARD ASSEMBLIES**

- A. Provide completed assemblies complying with ASTM C840 and GA-216.
  - 1. See PART 3 for finishing requirements.
- B. Interior Partitions Indicated as Acoustic("S" suffix in the Partition Type Indicator): Provide completed assemblies with the following characteristics:
  - 1. Acoustic Attenuation: STC of 45-49 calculated in accordance with ASTM E413, based on tests conducted in accordance with ASTM E90.
- C. Shaft Walls at HVAC Shafts: Provide completed assemblies with the following characteristics:

1. Air Pressure Within Shaft: Sustained loads of 5 lbf/sq ft with maximum mid-span deflection of L/240.
  2. Acoustic Attenuation: STC of 35-39 calculated in accordance with ASTM E413, based on tests conducted in accordance with ASTM E90.
- D. Shaft Walls at Elevator Shafts: Provide completed assemblies with the following characteristics:
1. Air Pressure Within Shaft: Intermittent loads of 5 lbf/sq ft with maximum mid-span deflection of L/240.
  2. Acoustic Attenuation: STC of 35-39 calculated in accordance with ASTM E413, based on tests conducted in accordance with ASTM E90.
- E. Fire Rated Assemblies: Provide completed assemblies complying with applicable code.
1. ICC IBC Item Numbers: Comply with applicable requirements of ICC IBC for the particular assembly.
  2. Gypsum Association File Numbers: Comply with requirements of GA-600 for the particular assembly.
  3. UL Assembly Numbers: Provide construction equivalent to that listed for the particular assembly in the current UL (FRD).

## 2.02 METAL FRAMING MATERIALS

- A. Manufacturers - Metal Framing, Connectors, and Accessories:
1. Basis of Design: Clarkwestern Dietrich Building Systems LLC: [www.clarkdietrich.com](http://www.clarkdietrich.com).
  2. Marino: [www.marinoware.com](http://www.marinoware.com).
  3. Phillips Manufacturing Company: [www.phillipsmfg.com](http://www.phillipsmfg.com).
- B. Non-Loadbearing Framing System Components: ASTM C645; galvanized sheet steel, of size and properties necessary to comply with ASTM C754 for the spacing indicated, with maximum deflection of wall framing of L/240 at 5 psf.
1. Exception: The minimum metal thickness and section properties requirements of ASTM C 645 are waived provided steel of 40 ksi minimum yield strength is used, the metal is continuously dimpled, the effective thickness is at least twice the base metal thickness, and maximum stud heights are determined by testing in accordance with ASTM E 72 using assemblies specified by ASTM C 754.
  2. Studs: "C" shaped with flat or formed webs.
  3. Runners: U shaped, sized to match studs.
  4. Ceiling Channels: C-shaped.
  5. Furring: Hat-shaped sections, minimum depth of 7/8 inch.
  6. Resilient Furring Channels: 1/2 inch depth, for attachment to substrate through one leg only.
    - a. Products:
      - 1) Same manufacturer as other framing materials.
      - 2) Substitutions: See Section 01 60 00 - Product Requirements.
- C. Loadbearing Studs for Application of Gypsum Board: As specified in Section 05 40 00.
- D. Shaft Wall Studs and Accessories: ASTM C645; galvanized sheet steel, of size and properties necessary to comply with ASTM C754 and specified performance requirements.
1. Products:
    - a. Same manufacturer as other framing materials.
- E. Ceiling Hangers: Type and size as specified in ASTM C754 for spacing required.
- F. Partition Head to Structure Connections: Provide mechanical anchorage devices that accommodate deflection using slotted holes, screws and anti-friction bushings, preventing rotation of studs while maintaining structural performance of partition.



1. Structural Performance: Maintain lateral load resistance and vertical movement capacity required by applicable code, when evaluated in accordance with AISI S100-12.
2. Material: ASTM A653/A653M steel sheet, SS Grade 50/340, with G60/Z180 hot dipped galvanized coating.
3. Provide components UL-listed for use in UL-listed fire-rated head of partition joint systems indicated on drawings.
4. Deflection and Firestop Track:
  - a. Provide mechanical anchorage devices as described above that accommodate deflection while maintaining the fire-rating of the wall assembly.
  - b. Products:
    - 1) FireTrak Corporation; Posi Klip.
    - 2) Metal-Lite, Inc.; The System.

### 2.03 BOARD MATERIALS

- A. Manufacturers - Gypsum-Based Board:
  1. American Gypsum Company: [www.americangypsum.com](http://www.americangypsum.com).
  2. CertainTeed Corporation: [www.certainteed.com](http://www.certainteed.com).
  3. Georgia-Pacific Gypsum: [www.gpgypsum.com](http://www.gpgypsum.com).
  4. National Gypsum Company: [www.nationalgypsum.com](http://www.nationalgypsum.com).
  5. Temple-Inland Building Product by Georgia-Pacific, LLC: [www.temple.com](http://www.temple.com).
  6. Basis of Design: USG Corporation: [www.usg.com](http://www.usg.com).
- B. Gypsum Wallboard: Paper-faced gypsum panels as defined in ASTM C1396/C1396M; sizes to minimize joints in place; ends square cut.
  1. Application: Use for vertical surfaces and ceilings, unless otherwise indicated.
  2. Glass mat faced gypsum panels as defined in ASTM C1658/C1658M, suitable for paint finish, of the same core type and thickness may be substituted for paper-faced board.
  3. Unfaced fiber-reinforced gypsum panels as defined in ASTM C1278/C1278M, suitable for paint finish, of the same core type and thickness may be substituted for paper-faced board.
  4. At Assemblies Indicated with Fire-Rating: Use type required by indicated tested assembly; if no tested assembly is indicated, use Type X board, UL or WH listed.
  5. Thickness:
    - a. Vertical Surfaces: 5/8 inch.
    - b. Ceilings: 5/8 inch.
    - c. Multi-Layer Assemblies: Thicknesses as indicated on drawings.
  6. Paper-Faced Products:
    - a. Georgia-Pacific Gypsum; ToughRock.
    - b. National Gypsum Company; Gold Bond Brand Gypsum Wallboard.
    - c. Temple-Inland Building Product by Georgia-Pacific, LLC; Gypsumboard and Gypsum Board Fire Resistant Panels Type X and Type TGC.
    - d. Basis of Design: USG Corporation; Sheetrock Brand Gypsum Panels.
  7. Mold Resistant Paper Faced Products:
    - a. American Gypsum Company; M-Bloc.
    - b. CertainTeed Corporation; ProRoc Brand Moisture & Mold Resistant Gypsum Board.
    - c. National Gypsum Company; Gold Bond Brand XP Gypsum Board.
    - d. Temple-Inland Building Product by Georgia-Pacific, LLC; ComfortGuard Mold Resistant Gypsum Board.
    - e. Basis of Design: USG Corporation; Sheetrock Brand Mold Tough Gypsum Panels.
    - f. USG Corporation; Sheetrock Brand Mold Tough Gypsum Panels AR.
  8. Glass Mat Faced Products:
    - a. Basis of Design: Georgia-Pacific Gypsum; DensArmor Plus.

- b. Georgia-Pacific Gypsum; DensArmor Plus Abuse-Resistant.
  - c. Temple-Inland Building Product by Georgia-Pacific, LLC; GreenGlass Interior Gypsum Board.
  - d. National Gypsum Company; Gold Bond eXP Fire-Shield Interior Extreme Gypsum Panel.
9. Unfaced Products:
- a. Basis of Design: USG Corporation; Fiberock Aqua-Tough Interior Panels.
  - b. USG Corporation; Fiberock Brand Panels--Abuse-Resistant.
- C. Impact Resistant Wallboard:
- 1. Application: High-traffic areas indicated.
  - 2. Mold Resistance: Score of 10, when tested in accordance with ASTM D3273.
  - 3. Paper-Faced Type: Gypsum wallboard as defined in ASTM C1396/C1396M.
  - 4. Unfaced Type: Interior fiber-reinforced gypsum panels as defined in ASTM C1278/C1278M.
  - 5. Type: Fire resistance rated Type X, UL or WH listed.
  - 6. Thickness: 5/8 inch.
  - 7. Edges: Tapered.
  - 8. Products:
    - a. National Gypsum Company; Gold Bond Hi-Impact Brand XP Wallboard.
    - b. Temple-Inland Building Product by Georgia-Pacific, LLC; ComfortGuard IR Impact Resistant.
    - c. Basis of Design: USG Corporation; Fiberock Brand Panels--VHI Abuse-Resistant.
- D. Backing Board For Wet Areas: One of the following products:
- 1. Application: Surfaces behind tile in wet areas including tub and shower surrounds and shower ceilings.
  - 2. Mold Resistance: Score of 10, when tested in accordance with ASTM D3273.
  - 3. Glass Mat Faced Board: Coated glass mat water-resistant gypsum backing panel as defined in ASTM C1178/C1178M.
    - a. Standard Type: Thickness 5/8 inch.
    - b. Fire Resistant Type: Type X core, thickness 5/8 inch.
    - c. Products:
      - 1) Basis of Design: Georgia-Pacific Gypsum; DensShield Tile Backer.
      - 2) National Gypsum Company; Gold Bond eXP Tile Backer.
      - 3) Temple-Inland Building Product by Georgia-Pacific, LLC; GreenGlass Tile Backer.
- E. Backing Board For Non-Wet Areas: Water-resistant gypsum backing board as defined in ASTM C1396/C1396M; sizes to minimum joints in place; ends square cut.
- 1. Application: Vertical surfaces behind thinset tile, except in wet areas.
  - 2. Mold Resistance: Score of 10, when tested in accordance with ASTM D3273.
  - 3. At Assemblies Indicated with Fire-Rating: Use type required by indicated tested assembly; if no tested assembly is indicated, use Type X board, UL or WH listed.
  - 4. Type: Regular and Type X, in locations indicated.
  - 5. Type X Thickness: 5/8 inch.
  - 6. Type C Thickness: 5/8 inch.
  - 7. Regular Board Thickness: 5/8 inch.
  - 8. Edges: Tapered.
  - 9. Products:
    - a. Basis of Design: Georgia-Pacific Gypsum; DensShield Tile Backer.
    - b. National Gypsum Company; Gold Bond Brand XP Gypsum Board.
    - c. Temple-Inland Building Product by Georgia-Pacific, LLC; ComfortGuard WR.

- d. USG Corporation; Sheetrock Brand Mold Tough Gypsum Panels.
- F. Backing Board For Stone Veneer at Millwork: One of the following products:
  - 1. Application: Surfaces behind stone at reception desk and nurse stations.
  - 2. ANSI Cement-Based Board: Non-gypsum-based; aggregated Portland cement panels with glass fiber mesh embedded in front and back surfaces complying with ANSI A118.9 or ASTM C1325.
    - a. Thickness: 1/2 inch.
    - b. Products:
      - 1) National Gypsum Company; PermaBase Brand Cement Board.
      - 2) National Gypsum Company; PermaBase Flex Brand Cement Board.
      - 3) USG Corporation; Durock Brand Cement Board.
- G. Backing Board for Exterior Stone Veneer: Non-gypsum-based, cementitious board complying with ASTM C1288.
  - 1. Application: Exterior substrait for stone veneer.
  - 2. Thickness: 1/2 inch.
  - 3. Products:
    - a. National Gypsum Company; PermaBase Brand Cement Board..
    - b. USG Corporation; Durock Brand Cement Board..
- H. Ceiling Board: Special sag resistant gypsum ceiling board as defined in ASTM C1396/C1396M; sizes to minimize joints in place; ends square cut.
  - 1. Application: Ceilings, unless otherwise indicated.
  - 2. Thickness: 5/8 inch.
  - 3. Edges: Tapered.
  - 4. Products:
    - a. Georgia-Pacific Gypsum; ToughRock Span 24 Ceiling Board.
    - b. National Gypsum Company; High Strength Brand Ceiling Board.
    - c. Temple-Inland Building Products by Georgia-Pacific, LLC; Span24 Ceiling Board.
    - d. Basis of Design: USG Corporation; Sheetrock Brand Sag-Resistant Interior Gypsum Ceiling Board.
- I. Shaftwall and Coreboard: Type X; 1 inch thick by 24 inches wide, beveled long edges, ends square cut.
  - 1. Paper Faced Type: Gypsum shaftliner board or gypsum coreboard as defined ASTM C1396/C1396M; water-resistant faces.
  - 2. Glass Mat Faced Type: Glass mat shaftliner gypsum panel or glass mat coreboard gypsum panel as defined in ASTM C1658/C1658M.
  - 3. Mold Resistance: Score of 10, when tested in accordance with ASTM D3273.
  - 4. Products:
    - a. American Gypsum; Shaft Liner.
    - b. CertainTeed Corporation; ProRoc Brand Shaftliner Type X.
    - c. National Gypsum Company; Gold Bond Brand 1" Fire-Shield Shaftliner.
    - d. National Gypsum Company; Gold Bond Brand 1" Fire-Shield Shaftliner XP (mold-resistant).
    - e. Temple-Inland Building Products by Georgia-Pacific, LLC; GreenGlass Liner Panel.
    - f. Temple-Inland Building Products by Georgia-Pacific, LLC; SilentGuard Gypsum Shaftliner.
    - g. USG Corporation; Sheetrock Gypsum Liner Panels.
    - h. Basis of Design: USG Corporation; Sheetrock Gypsum Liner Panels--Enhanced (mold-resistant).

## **2.04 ACCESSORIES**

- A. Acoustic Insulation: ASTM C665; preformed glass fiber, friction fit type, unfaced. Thickness: 2 inch.
- B. Acoustic Insulation: 1; preformed glass fiber, friction fit type, unfaced.
- C. Acoustic Sealant: Acrylic emulsion latex or water-based elastomeric sealant; do not use solvent-based non-curing butyl sealant.
- D. Joint Materials: ASTM C475 and as recommended by gypsum board manufacturer for project conditions.
  - 1. Tape: 2 inch wide, coated glass fiber tape for joints and corners, except as otherwise indicated.
  - 2. Tape: 2 inch wide, creased paper tape for joints and corners, except as otherwise indicated.
  - 3. Ready-mixed vinyl-based joint compound.
  - 4. Chemical hardening type compound.
- E. High Build Drywall Surfer: Vinyl acrylic latex-based coating for spray application, designed to take the place of skim coating and separate paint primer in achieving Level 5 finish.
- F. Textured Finish Materials: Latex-based compound; plain.
- G. Screws for Fastening of Gypsum Panel Products to Cold-Formed Steel Studs Less than 0.033 inch in Thickness and Wood Members: ASTM C1002; self-piercing tapping screws, corrosion resistant.
- H. Screws for Fastening of Gypsum Panel Products to Steel Members from 0.033 to 0.112 inch in Thickness: ASTM C954; steel drill screws, corrosion resistant.

## **PART 3 EXECUTION**

### **3.01 EXAMINATION**

- A. Verify that project conditions are appropriate for work of this section to commence.

### **3.02 SHAFT WALL INSTALLATION**

- A. Shaft Wall Framing: Install in accordance with manufacturer's installation instructions.
  - 1. Fasten runners to structure with short leg to finished side, using appropriate power-driven fasteners at not more than 24 inches on center.
  - 2. Install studs at spacing required to meet performance requirements.
- B. Shaft Wall Liner: Cut panels to accurate dimension and install sequentially between special friction studs.
  - 1. On walls over sixteen feet high, screw-attach studs to runners top and bottom.
  - 2. Seal perimeter of shaft wall and penetrations with acoustical sealant.

### **3.03 FRAMING INSTALLATION**

- A. Metal Framing: Install in accordance with ASTM C754 and manufacturer's instructions.
- B. Suspended Ceilings and Soffits: Space framing and furring members as indicated.
  - 1. Level ceiling system to a tolerance of 1/1200.
  - 2. Laterally brace entire suspension system.
- C. Studs: Space studs at 16 inches on center.
  - 1. Extend partition framing to structure where indicated and to ceiling in other locations.
  - 2. Partitions Terminating at Ceiling: Attach ceiling runner securely to ceiling track in accordance with manufacturer's instructions.
  - 3. Partitions Terminating at Structure: Attach top runner to structure, maintain clearance between top of studs and structure, and connect studs to track using specified mechanical

devices in accordance with manufacturer's instructions; verify free movement of top of stud connections; do not leave studs unattached to track.

- D. Openings: Reinforce openings as required for weight of doors or operable panels, using not less than double studs at jambs.
- E. Standard Wall Furring: Install at concrete and masonry walls scheduled to receive gypsum board, not more than 4 inches from floor and ceiling lines and abutting walls. Secure in place on alternate channel flanges at maximum 24 inches on center.
  - 1. Orientation: Horizontal.
  - 2. Spacing: As indicated.
- F. Acoustic Furring: Install resilient channels at maximum 24 inches on center. Locate joints over framing members.
- G. Furring for Fire Ratings: Install as required for fire resistance ratings indicated and to GA-600 requirements.
- H. Blocking: Install wood blocking for support of:
  - 1. Framed openings.
  - 2. Wall mounted cabinets.
  - 3. Plumbing fixtures.
  - 4. Toilet partitions.
  - 5. Toilet accessories.
  - 6. Wall mounted door hardware.

### **3.04 ACOUSTIC ACCESSORIES INSTALLATION**

- A. Acoustic Insulation: Place tightly within spaces, around cut openings, behind and around electrical and mechanical items within partitions, and tight to items passing through partitions.
- B. Acoustic Sealant: Install in accordance with manufacturer's instructions.
  - 1. Place one bead continuously on substrate before installation of perimeter framing members.
  - 2. Place continuous bead at perimeter of each layer of gypsum board.
  - 3. Seal around all penetrations by conduit, pipe, ducts, and rough-in boxes, except where firestopping is provided.

### **3.05 BOARD INSTALLATION**

- A. Comply with ASTM C 840, GA-216, and manufacturer's instructions. Install to minimize butt end joints, especially in highly visible locations.
- B. Single-Layer Non-Rated: Install gypsum board in most economical direction, with ends and edges occurring over firm bearing.
  - 1. Exception: Tapered edges to receive joint treatment at right angles to framing.
- C. Double-Layer Non-Rated: Use gypsum board for first layer, placed parallel to framing or furring members, with ends and edges occurring over firm bearing. Use glass mat faced gypsum board at exterior walls and at other locations as indicated. Place second layer perpendicular to framing or furring members. Offset joints of second layer from joints of first layer.
- D. Fire-Rated Construction: Install gypsum board in strict compliance with requirements of assembly listing.
- E. Exposed Gypsum Board in Interior Wet Areas: Seal joints, cut edges, and holes with water-resistant sealant.
- F. Cementitious Backing Board: Install over steel framing members and plywood substrate where indicated, in accordance with ANSI A108.11 and manufacturer's instructions.
- G. Installation on Metal Framing: Use screws for attachment of gypsum board except face layer of non-rated double-layer assemblies, which may be installed by means of adhesive lamination.

H. Curved Surfaces: Apply gypsum board to curved substrates in accordance with GA-226.

### **3.06 INSTALLATION OF TRIM AND ACCESSORIES**

- A. Control Joints: Place control joints consistent with lines of building spaces and as indicated.
  - 1. Not more than 30 feet apart on walls and ceilings over 50 feet long.
- B. Corner Beads: Install at external corners, using longest practical lengths.
- C. Edge Trim: Install at locations where gypsum board abuts dissimilar materials.

### **3.07 JOINT TREATMENT**

- A. Glass Mat Faced Gypsum Board and Exterior Glass Mat Faced Sheathing: Use fiberglass joint tape, bedded and finished with chemical hardening type joint compound.
- B. Paper Faced Gypsum Board: Use paper joint tape, bedded with ready-mixed vinyl-based joint compound and finished with ready-mixed vinyl-based joint compound.
- C. Finish gypsum board in accordance with levels defined in ASTM C840, as follows:
  - 1. Level 5: Walls and ceilings to receive gloss paint finish and other areas specifically indicated.
  - 2. Level 3: Walls to receive textured wall finish.
  - 3. Level 1: Fire rated wall areas above finished ceilings, whether or not accessible in the completed construction.
  - 4. Level 0: Temporary partitions.
- D. Tape, fill, and sand exposed joints, edges, and corners to produce smooth surface ready to receive finishes.
  - 1. Feather coats of joint compound so that camber is maximum 1/32 inch.
  - 2. Taping, filling and sanding is not required at base layer of double layer applications.
- E. Where Level 5 finish is indicated, spray apply high build drywall surfacer over entire surface after joints have been properly treated; achieve a flat and tool mark-free finish.

### **3.08 TEXTURE FINISH**

- A. Apply finish texture coating by means of spraying apparatus in accordance with manufacturer's instructions and to match approved sample.

### **3.09 TOLERANCES**

- A. Maximum Variation of Finished Gypsum Board Surface from True Flatness: 1/8 inch in 10 feet in any direction.

**END OF SECTION**

**SECTION 09 91 13**  
**EXTERIOR PAINTING**

**PART 1 GENERAL**

**1.01 SECTION INCLUDES**

- A. Surface preparation.
- B. Field application of paints.
- C. Scope: Finish exterior surfaces exposed to view, unless fully factory-finished and unless otherwise indicated, including the following:
  - 1. Exposed surfaces of steel lintels and ledge angles.
  - 2. Mechanical and Electrical:
    - a. On the roof and outdoors, paint equipment that is exposed to weather or to view, including factory-finished materials.
- D. Do Not Paint or Finish the Following Items:
  - 1. Items factory-finished unless otherwise indicated; materials and products having factory-applied primers are not considered factory finished.
  - 2. Items indicated to receive other finishes.
  - 3. Items indicated to remain unfinished.
  - 4. Fire rating labels, equipment serial number and capacity labels, and operating parts of equipment.
  - 5. Non-metallic roofing and flashing.
  - 6. Stainless steel, anodized aluminum, bronze, terne coated stainless steel, zinc, and lead.
  - 7. Marble, granite, slate, and other natural stones.
  - 8. Exterior paving and other hardscape, unless specifically indicated.
  - 9. Ceramic and other types of tiles.
  - 10. Brick, glass unit masonry, architectural concrete, cast stone, integrally colored plaster and stucco.
  - 11. Exterior insulation and finish system (EIFS).
  - 12. Glass.

**1.02 RELATED REQUIREMENTS**

- A. Section 01 61 16 - Volatile Organic Compound (VOC) Content Restrictions.
- B. Section 05 50 00 - Metal Fabrications: Shop-primed items. Coordinate compatibility of shop coats with finish coats specified herein.
- C. Section 09 91 23 - Interior Painting.
- D. Section 32 17 23.13 - Painted Pavement Markings: Painted pavement markings.

**1.03 DEFINITIONS**

- A. Conform to ASTM D16 for interpretation of terms used in this section.
- B. MPI: Master Painters Institute.
- C. Gloss, Sheen: As defined by MPI Gloss Levels GL1 (flat) thru GL7 (high gloss). (traditional "gloss" sheen is GL6).

**1.04 REFERENCE STANDARDS**

- A. ASTM D16 - Standard Terminology for Paint, Related Coatings, Materials, and Applications; 2014.
- B. MPI (APL) - Master Painters Institute Approved Products List; Master Painters and Decorators Association; current edition, [www.paintinfo.com](http://www.paintinfo.com).

- C. MPI (APSM) - Master Painters Institute Architectural Painting Specification Manual; Current Edition, [www.paintinfo.com](http://www.paintinfo.com).
- D. SSPC-SP 1 - Solvent Cleaning; 2015.
- E. SSPC-SP 2 - Hand Tool Cleaning; 1982 (Ed. 2004).
- F. SSPC-SP 6 - Commercial Blast Cleaning; 2007.
- G. SSPC-SP 13 - Surface Preparation of Concrete; (Reaffirmed 2015); 2003.

#### **1.05 SUBMITTALS**

- A. See Section 01 30 00 - Administrative Requirements, for submittal procedures.
- B. Product Data: Provide complete list of products to be used, with the following information for each:
  - 1. Manufacturer's name, product name, code and/or catalog number, and general product description (e.g. "latex, exterior, 100% acrylic, MPI Gloss Level 3").
  - 2. MPI category number (e.g. MPI #15).
  - 3. Cross-reference to specified paint system(s) product is to be used in; include description of each system.
- C. Samples: Submit two paper "draw down" samples, 8-1/2 by 11 inches in size, illustrating range of colors available for each finishing product specified.
  - 1. Where sheen (MPI Gloss Level) is specified, submit samples in only that sheen.
  - 2. Where sheen is not specified, discuss sheen options with Architect before preparing samples, to eliminate sheens definitely not required.
  - 3. Allow 30 days for approval process, after receipt of complete samples by Architect.
  - 4. Paint color submittals will not be considered until color submittals for major materials not to be painted, such as masonry, have been approved.
- D. Samples: Submit two painted samples, illustrating selected colors and textures for each color and system selected with specified coats cascaded. Submit on aluminum sheet, minimum 8 by 10 inches in size.
- E. Certification: By manufacturer that paints and finishes comply with VOC limits specified.
- F. Manufacturer's Instructions: Indicate special surface preparation procedures.
- G. Maintenance Data: Submit data including finish schedule showing where each product/color/finish was used, product technical data sheets, material safety data sheets (MSDS), care and cleaning instructions, touch-up procedures, repair of painted and finished surfaces, and color samples of each color and finish used.
- H. Maintenance Materials: Furnish the following for Owner's use in maintenance of project.
  - 1. See Section 01 60 00 - Product Requirements, for additional provisions.
  - 2. Extra Paint and Finish Materials: 1 gallon of each color; from the same product run, store where directed.
  - 3. Label each container with color in addition to the manufacturer's label.

#### **1.06 QUALITY ASSURANCE**

- A. Manufacturer Qualifications: Company specializing in manufacturing the products specified, with minimum three years experience.
- B. Applicator Qualifications: Company specializing in performing the type of work specified with minimum three years experience and approved by manufacturer.

#### **1.07 DELIVERY, STORAGE, AND HANDLING**

- A. Deliver products to site in sealed and labeled containers; inspect to verify acceptability.



- B. Container Label: Include manufacturer's name, type of paint, brand name, lot number, brand code, coverage, surface preparation, drying time, cleanup requirements, color designation, and instructions for mixing and reducing.
- C. Paint Materials: Store at minimum ambient temperature of 45 degrees F and a maximum of 90 degrees F, in ventilated area, and as required by manufacturer's instructions.

#### **1.08 FIELD CONDITIONS**

- A. Do not apply materials when surface and ambient temperatures are outside the temperature ranges required by the paint product manufacturer.
- B. Follow manufacturer's recommended procedures for producing best results, including testing of substrates, moisture in substrates, and humidity and temperature limitations.
- C. Do not apply exterior paint and finishes during rain or snow, or when relative humidity is outside the humidity ranges required by the paint product manufacturer.
- D. Minimum Application Temperatures for Latex Paints: 50 degrees F for exterior; unless required otherwise by manufacturer's instructions.
- E. Provide lighting level of at least 80 ft candles measured mid-height at substrate surface.

### **PART 2 PRODUCTS**

#### **2.01 MANUFACTURERS**

- A. Provide paints and finishes from the same manufacturer to the greatest extent possible.
  - 1. In the event that a single manufacturer does not make an MPI-approved product in a specified MPI category, an exception may be permitted, provided approval by Architect is obtained using the applicable procedures for substitutions specified Section 01 60 00 - Product Requirements.
  - 2. Substitution of other products by the same manufacturer is preferred over substitution of products by a different manufacturer.
- B. Acceptable Manufacturers - Paint Products:
  - 1. Benjamin Moore & Co: [www.benjaminmoore.com](http://www.benjaminmoore.com).
  - 2. PPG Paints: [www.ppgpaints.com](http://www.ppgpaints.com).
  - 3. Sherwin-Williams Company: [www.sherwin-williams.com](http://www.sherwin-williams.com).
- C. Transparent Finishes:
  - 1. Benjamin Moore & Co: [www.benjaminmoore.com](http://www.benjaminmoore.com).
  - 2. PPG Paints: [www.ppgpaints.com](http://www.ppgpaints.com).
  - 3. Sherwin-Williams Company: [www.sherwin-williams.com](http://www.sherwin-williams.com).
- D. Primers/Sealers: Same manufacturer as top coats.
- E. Substitutions: Not permitted, except as specified in Paragraph 2.01 A above.

#### **2.02 PAINTS AND FINISHES - GENERAL**

- A. Paints and Finishes: Ready mixed, unless required to be a field-catalyzed paint.
  - 1. For each application where MPI paint numbers are specified, provide one of the products that is specified herein and listed under the specified MPI category (MPI number, MPI #) in the Master Painters Institute Approved Product List, current edition, available at [www.paintinfo.com](http://www.paintinfo.com), for specified MPI categories, unless otherwise indicated.
  - 2. Provide paints and finishes of a soft paste consistency, capable of being readily and uniformly dispersed to a homogeneous coating, with good flow and brushing properties, and capable of drying or curing free of streaks or sags.
  - 3. Provide materials that are compatible with one another and the substrates indicated under conditions of service and application, as demonstrated by manufacturer based on testing and field experience.

4. For opaque finishes, tint each coat including primer coat and intermediate coats, one-half shade lighter than succeeding coat, with final finish coat as base color.
  5. Supply each paint material in quantity required to complete entire project's work from a single production run.
  6. Do not reduce, thin, or dilute paint or finishes or add materials unless such procedure is specifically described in manufacturer's product instructions. Follow manufacturer's instructions.
- B. Volatile Organic Compound (VOC) Content: Comply with Section 01 61 16.
- C. Flammability: Comply with applicable code for surface burning characteristics.
- D. Sheens: Provide the sheens specified; where sheen is not specified, sheen will be selected later by Architect from the manufacturer's full line.
- E. Colors: As indicated on drawings.

### **2.03 PAINT SYSTEMS - EXTERIOR**

- A. Paint E-OP - (Exterior - Opaque) Exterior Surfaces to be Painted, Unless Otherwise Indicated: Including concrete masonry units (CMU), poured-in-place and tilt-up concrete, brick, wood, and fiber cement board.
1. Two top coats over one coat primer.
  2. Top Coats: Latex, Exterior, Low Sheen; MPI #15 - 100% Acrylic, Gloss Level 3/4 ("egg-shell-like" or satin).
    - a. Products:
      - 1) Benjamin Moore Ultra Spec EXT Satin Finish N448/K448. (MPI #15)
      - 2) PPG Speedhide Exterior 100% Acrylic Latex Satin 6-2045XI Series. (MPI #15)
      - 3) Sherwin-Williams A-100 Exterior Latex Low Sheen A12-100 Series. (MPI #15)
      - 4) Substitutions: Not permitted.
  3. Top Coat Sheen:
    - a. Eggshell or satin: MPI gloss level 3 or 4; use this sheen at all locations except exterior metal and elsewhere where specifically indicated otherwise.
  4. Primers: As specified under "PRIMERS" below for the applicable substrate, unless otherwise recommended by the top coat manufacturer.
- B. Paint ME-OP-3L - (Metal, Exterior - Opaque - 3 Coat, Latex) Ferrous Metals (Shop-primed, Unprimed, or Galvanized), Latex, 3 Coat:
1. Primer: One coat (or touch-up of shop coat), as specified under "PRIMERS" below for the applicable substrate, unless otherwise recommended by the top coat manufacturer.
  2. Top Coats: Two coats of MPI #164, Light Industrial Coating, Exterior, Water Based, Gloss Level 6 (gloss).
    - a. Products:
      - 1) Benjamin Moore Ultra Spec HP DTM 100% Acrylic Latex Gloss HP28/FP28. (MPI #164)
      - 2) PPG High Performance Coatings Pitt-Tech Plus Int/Ext High Gloss Industrial Enamel 90-1310. (MPI #164)
      - 3) Sherwin-Williams Pro Industrial DTM Acrylic Gloss, B66W01051. (MPI #164)
      - 4) Substitutions: Not permitted.

### **2.04 PRIMERS**

- A. Primers: Provide the following unless other primer is required or recommended by manufacturer of top coats.
1. For Concrete (Cast-in-Place and Tilt-Up), Cement Board, and Clay Masonry (Brick): Primer, Alkali Resistant, Water Based; MPI #3 or MPI #3 X-Green.
    - a. Products:

- 1) Benjamin Moore Super Spec Interior/Exterior High-Build Masonry Primer N068. (MPI #3)
  - 2) PPG Perma-Crete Int/Ext Alkali Resistant Primer 4-603. (MPI #3)
  - 3) Sherwin-Williams Loxon Concrete & Masonry Primer/Sealer/Stain Killer A24W8300. (MPI #3)
  - 4) Substitutions: Not permitted.
2. For Concrete Masonry Units (CMU): Block Filler, Latex, Interior/Exterior; MPI #4 or MPI #4 X-Green.
    - a. Products:
      - 1) Benjamin Moore Super Spec Int/Ext High-Build Block Filler 206/K206. (MPI #4)
      - 2) PPG Interior/Exterior Masonry HiFill Latex Block Filler 6-15. (MPI #4)
      - 3) Sherwin-Williams Loxon Block Surfacer A24W00200/A24WQ8200. (MPI #4)
      - 4) Substitutions: Not permitted.
  3. For Unprimed Metal: Primer, Alkyd, Anti-Corrosive for Metal; MPI #79, except where indicated otherwise.
    - a. Products:
      - 1) Benjamin Moore Super Spec HP D.T.M. Alkyd Low Lustre, P23/KP23. (MPI #79)
      - 2) PPG Speedhide Int/Ext Rust In hibitive Steel Primer, 6-212. (MPI #79)
      - 3) Sherwin-Williams Protective & Marine Kem Kromik Universal Metal Primer, B50WZ1. (MPI #79)
      - 4) Substitutions: Not permitted.
  4. For Galvanized Metal: Primer, Galvanized, Water Based; MPI #134, except where indicated otherwise.
    - a. Products:
      - 1) Benjamin Moore Super Spec HP Acrylic Metal Primer P04/KP04. (MPI #134)
      - 2) PPG High Performance Coatings 100% Acrylic DTM Industrial Primer 90-912. (MPI #134)
      - 3) Sherwin-Williams Pro Industrial Pro-Cryl Universal Primer, B66W310. (MPI #134)
      - 4) Substitutions: Not permitted.

## **2.05 ACCESSORY MATERIALS**

- A. Accessory Materials: Provide primers, sealers, cleaning agents, cleaning cloths, sanding materials, and clean-up materials as required for final completion of painted surfaces.
- B. Patching Material: Latex filler.
- C. Fastener Head Cover Material: Latex filler.

## **PART 3 EXECUTION**

### **3.01 EXAMINATION**

- A. Do not begin application of paints and finishes until substrates have been properly prepared.
- B. Verify that surfaces are ready to receive work as instructed by the product manufacturer.
- C. Examine surfaces scheduled to be finished prior to commencement of work. Report any condition that may potentially effect proper application.
- D. If substrate preparation is the responsibility of another installer, notify Architect of unsatisfactory preparation before proceeding.
- E. Test shop-applied primer for compatibility with subsequent cover materials.

### **3.02 PREPARATION**

- A. Clean surfaces thoroughly and correct defects prior to application.

- B. Prepare surfaces using the methods recommended by the manufacturer for achieving the best result for the substrate under the project conditions.
- C. Remove or repair existing paints or finishes that exhibit surface defects.
- D. Remove or mask surface appurtenances, including electrical plates, hardware, light fixture trim, escutcheons, and fittings, prior to preparing surfaces for finishing.
- E. Seal surfaces that might cause bleed through or staining of topcoat.
- F. Remove mildew from impervious surfaces by scrubbing with solution of tetra-sodium phosphate and bleach. Rinse with clean water and allow surface to dry.
- G. Concrete:
  - 1. Remove release agents, curing compounds, efflorescence, and chalk. Do not coat surfaces if moisture content or alkalinity of surfaces to be coated exceeds that permitted in manufacturer's written instructions.
  - 2. Prepare surface as recommended by top coat manufacturer and according to SSPC-SP 13.
- H. Masonry:
  - 1. Remove efflorescence and chalk. Do not coat surfaces if moisture content or alkalinity of surfaces or if alkalinity of mortar joints exceed that permitted in manufacturer's written instructions. Allow to dry.
  - 2. Prepare surface as recommended by top coat manufacturer.
  - 3. Clean surfaces with pressurized water. Use pressure range of 600 to 1500 psi at 6 to 12 inches. Allow to dry.
- I. Galvanized Surfaces:
  - 1. Remove surface contamination and oils and wash with solvent according to SSPC-SP 1.
  - 2. Prepare surface according to SSPC-SP 2.
- J. Ferrous Metal:
  - 1. Solvent clean according to SSPC-SP1.
  - 2. Shop-Primed Surfaces: Sand and scrape to remove loose primer and rust. Feather edges to make touch-up patches inconspicuous. Clean surfaces with solvent. Prime bare steel surfaces.
  - 3. Remove rust, loose mill scale, and other foreign substances using using methods recommended in writing by paint manufacturer and blast cleaning according to SSPC-SP 6 "Commercial Blast Cleaning". Protect from corrosion until coated.
- K. Metal Doors to be Painted: Prime metal door top and bottom edge surfaces.

### **3.03 APPLICATION**

- A. Remove unfinished louvers, grilles, covers, and access panels on mechanical and electrical components and paint separately.
- B. Apply products in accordance with manufacturer's written instructions and recommendations in "MPI Architectural Painting Specification Manual".
- C. Where adjacent sealant is to be painted, do not apply finish coats until sealant is applied.
- D. Do not apply finishes to surfaces that are not dry. Allow applied coats to dry before next coat is applied.
- E. Apply each coat to uniform appearance.
- F. Dark Colors and Deep Clear Colors: Regardless of number of coats specified, apply additional coats until complete hide is achieved.
- G. Sand wood and metal surfaces lightly between coats to achieve required finish.

- H. Vacuum clean surfaces of loose particles. Use tack cloth to remove dust and particles just prior to applying next coat.
- I. Reinstall electrical cover plates, hardware, light fixture trim, escutcheons, and fittings removed prior to finishing.

**3.04 FIELD QUALITY CONTROL**

- A. See Section 01 40 00 - Quality Requirements, for general requirements for field inspection.

**3.05 CLEANING**

- A. Collect waste material that could constitute a fire hazard, place in closed metal containers, and remove daily from site.

**3.06 PROTECTION**

- A. Protect finishes until completion of project.
- B. Touch-up damaged finishes after Substantial Completion.

**END OF SECTION**

**SECTION 09 91 23**  
**INTERIOR PAINTING**

**PART 1 GENERAL**

**1.01 SECTION INCLUDES**

- A. Surface preparation.
- B. Field application of paints.
- C. Scope: Finish interior surfaces exposed to view, unless fully factory-finished and unless otherwise indicated.
- D. Do Not Paint or Finish the Following Items:
  - 1. Items factory-finished unless otherwise indicated; materials and products having factory-applied primers are not considered factory finished.
  - 2. Items indicated to receive other finishes.
  - 3. Items indicated to remain unfinished.
  - 4. Fire rating labels, equipment serial number and capacity labels, bar code labels, and operating parts of equipment.
  - 5. Floors, unless specifically indicated.
  - 6. Glass.
  - 7. Concealed pipes, ducts, and conduits.

**1.02 RELATED REQUIREMENTS**

- A. Section 01 61 16 - Volatile Organic Compound (VOC) Content Restrictions.
- B. Section 09 91 13 - Exterior Painting.

**1.03 SUBMITTALS**

- A. See Section 01 30 00 - Administrative Requirements, for submittal procedures.

**1.04 QUALITY ASSURANCE**

**PART 2 PRODUCTS**

**2.01 PAINTS AND FINISHES - GENERAL**

- A. Paints and Finishes: Ready mixed, unless intended to be a field-catalyzed paint.
  - 1. Provide paints and finishes of a soft paste consistency, capable of being readily and uniformly dispersed to a homogeneous coating, with good flow and brushing properties, and capable of drying or curing free of streaks or sags.
  - 2. Supply each paint material in quantity required to complete entire project's work from a single production run.
  - 3. Do not reduce, thin, or dilute paint or finishes or add materials unless such procedure is specifically described in manufacturer's product instructions.

**PART 3 EXECUTION**

**3.01 PREPARATION**

- A. Clean surfaces thoroughly and correct defects prior to application.
- B. Prepare surfaces using the methods recommended by the manufacturer for achieving the best result for the substrate under the project conditions.
- C. Remove or mask surface appurtenances, including electrical plates, hardware, light fixture trim, escutcheons, and fittings, prior to preparing surfaces or finishing.
- D. Seal surfaces that might cause bleed through or staining of topcoat.

**3.02 APPLICATION**

- A. Apply products in accordance with manufacturer's written instructions and recommendations in "MPI Architectural Painting Specification Manual".
- B. Do not apply finishes to surfaces that are not dry. Allow applied coats to dry before next coat is applied.
- C. Apply each coat to uniform appearance in thicknesses specified by manufacturer.
- D. Vacuum clean surfaces of loose particles. Use tack cloth to remove dust and particles just prior to applying next coat.
- E. Reinstall electrical cover plates, hardware, light fixture trim, escutcheons, and fittings removed prior to finishing.

**END OF SECTION**

**SECTION 09 96 00**  
**HIGH-PERFORMANCE COATINGS**

**PART 1 GENERAL**

**1.01 SECTION INCLUDES**

- A. High performance coatings.
- B. Surface preparation.

**1.02 RELATED REQUIREMENTS**

- A. Section 09 91 13 - Exterior Painting.

**1.03 REFERENCE STANDARDS**

- A. ASTM D4258 - Standard Practice for Surface Cleaning Concrete for Coating; 2005 (Reapproved 2012).
- B. MPI (APL) - Master Painters Institute Approved Products List; Master Painters and Decorators Association; current edition, [www.paintinfo.com](http://www.paintinfo.com).
- C. MPI (APSM) - Master Painters Institute Architectural Painting Specification Manual; Current Edition, [www.paintinfo.com](http://www.paintinfo.com).

**1.04 SUBMITTALS**

- A. See Section 01 30 00 - Administrative Requirements for submittal procedures.
- B. Product Data: Provide complete list of all products to be used, with the following information for each:
  - 1. Manufacturer's name, product name and/or catalog number, and general product category (e.g. "alkyd enamel").
  - 2. MPI product number (e.g. MPI #47).
  - 3. Cross-reference to specified coating system(s) product is to be used in; include description of each system.
- C. Manufacturer's Certificate: Certify that products meet or exceed specified requirements.
- D. Manufacturer's Installation Instructions: Indicate special procedures and perimeter conditions requiring special attention.
- E. Maintenance Data: Include cleaning procedures and repair and patching techniques.
- F. Maintenance Materials: Furnish the following for Owner's use in maintenance of project.
  - 1. Extra Coating Materials: 1 gallon of each type and color.
  - 2. Label each container with manufacturer's name, product number, color number, and room names and numbers where used.

**1.05 QUALITY ASSURANCE**

- A. Manufacturer Qualifications: Company specializing in manufacturing the Products specified in this section with minimum three years documented experience.
- B. Applicator Qualifications: Company specializing in performing the work of this section with minimum five years documented experience.

**1.06 DELIVERY, STORAGE, AND HANDLING**

- A. Deliver products to site in sealed and labeled containers; inspect to verify acceptability.
- B. Container Label: Include manufacturer's name, type of coating, brand name, lot number, brand code, coverage, surface preparation, drying time, cleanup requirements, color designation, and instructions for mixing and reducing.
- C. Coating Materials: Store at minimum ambient temperature of 45 degrees F and a maximum of 90 degrees F, in ventilated area, and as required by manufacturer's instructions.



### **1.07 FIELD CONDITIONS**

- A. Follow manufacturer's recommended procedures for producing best results, including testing of substrates, moisture in substrates, and humidity and temperature limitations.
- B. Do not install materials when temperature is below 55 degrees F or above 90 degrees F.
- C. Maintain this temperature range, 24 hours before, during, and 72 hours after installation of coating.
- D. Restrict traffic from area where coating is being applied or is curing.

### **1.08 WARRANTY**

- A. See Section 01 78 00 - Closeout Submittals, for additional warranty requirements.
- B. Warranty: Include coverage for bond to substrate.

## **PART 2 PRODUCTS**

### **2.01 MANUFACTURERS**

- A. High-Performance Coatings:
  - 1. PPG Paints: [www.ppgpaints.com](http://www.ppgpaints.com).
  - 2. Pratt & Lambert Paints: [www.prattandlambert.com](http://www.prattandlambert.com).
  - 3. Sherwin-Williams Company: [www.protective.sherwin-williams.com/industries](http://www.protective.sherwin-williams.com/industries).
  - 4. Tnemec Company, Inc: [www.tnemec.com](http://www.tnemec.com).
  - 5. Substitutions: Section 01 60 00 - Product Requirements.

### **2.02 TOP COAT MATERIALS**

- A. Elastomeric Coating for cmu:
  - 1. Number of Coats: Two.
  - 2. Product Characteristics:
    - a. Comply with the performance requirements specified above for moderate exposure.
  - 3. Top Coat(s): Exterior Pigmented Elastomeric, Water Based; MPI #113.
    - a. Sheen: Flat.
    - b. Products:
      - 1) Dow Corning Corporation; AllGuard Silicone Elastomeric Coating with AllGuard Primer: [www.dowcorning.com/construction/sle](http://www.dowcorning.com/construction/sle).
      - 2) Substitutions: Section 01 60 00 - Product Requirements.
  - 4. Primer: As recommended by coating manufacturer for specific substrate.
- B. Shellac: Pure, white type.

### **2.03 ACCESSORY MATERIALS**

- A. Accessory Materials: Provide all primers, sealers, cleaning agents, cleaning cloths, sanding materials, and clean-up materials as required for final completion of coated surfaces.

## **PART 3 EXECUTION**

### **3.01 EXAMINATION**

- A. Verify existing conditions before starting work.
- B. Do not begin application of coatings until substrates have been properly prepared.
- C. Verify that substrate surfaces are ready to receive work as instructed by the coating manufacturer. Obtain and follow manufacturer's instructions for examination and testing of substrates.
- D. Examine surfaces scheduled to be finished prior to commencement of work. Report any condition that may potentially affect proper application.

- E. Measure moisture content of surfaces using an electronic moisture meter. Do not apply finishes unless moisture content of surfaces are below the following maximums:
  - 1. Masonry, Concrete, and Concrete Unit Masonry: 12 percent.
- F. Masonry: Verify masonry joints are struck flush.
- G. Proceed with coating application only after unacceptable conditions have been corrected.
  - 1. Commencing coating application constitutes Contractor's acceptance of substrates and conditions.

### **3.02 PREPARATION**

- A. Clean surfaces of loose foreign matter.
- B. Remove substances that would bleed through finished coatings. If unremovable, seal surface with shellac.
- C. Masonry:
  - 1. Remove efflorescence and chalk. Do not coat surfaces if moisture content or alkalinity of surfaces or if alkalinity of mortar joints exceed that permitted in manufacturer's written instructions. Allow to dry.
  - 2. Prepare surface as recommended by coating manufacturer.
- D. Protect adjacent surfaces and materials not receiving coating from spatter and overspray; mask if necessary to provide adequate protection. Repair damage.

### **3.03 PRIMING**

- A. Apply primer to all surfaces, unless specifically not required by coating manufacturer. Apply in accordance with coating manufacturer's instructions.
- B. Concrete Masonry: Apply masonry filler to thickness required to fill holes and produce smooth surface; minimum thickness of 30 mils.

### **3.04 COATING APPLICATION**

- A. Apply coatings in accordance with manufacturer's written instructions, to thicknesses specified and recommendations in "MPI Architectural Painting and Specification Manual".
- B. Apply in uniform thickness coats, without runs, drips, pinholes, brush marks, or variations in color, texture, or finish. Finish edges, crevices, corners, and other changes in dimension with full coating thickness.

### **3.05 FIELD QUALITY CONTROL**

- A. See Section 01 40 00 - Quality Requirements, for general requirements for field inspection.

### **3.06 CLEANING**

- A. Collect waste material that could constitute a fire hazard, place in closed metal containers, and remove daily from site.
- B. Clean surfaces immediately of overspray, splatter, and excess material.
- C. See Section 01 74 19 - Construction Waste Management and Disposal, for additional requirements.

### **3.07 PROTECTION**

- A. Protect finished work from damage.

**END OF SECTION**

**SECTION 09 97 23**  
**CONCRETE AND MASONRY COATINGS**

**PART 1 GENERAL**

**1.01 SECTION INCLUDES**

- A. High build, moisture resistant textured concrete and masonry coatings.

**1.02 RELATED REQUIREMENTS**

- A. Section 01 61 16 - Volatile Organic Compound (VOC) Content Restrictions.
- B. Section 09 91 13 - Exterior Painting.

**1.03 REFERENCE STANDARDS**

- A. ASTM B117 - Standard Practice for Operating Salt Spray (Fog) Apparatus; 2011.
- B. ASTM E84 - Standard Test Method for Surface Burning Characteristics of Building Materials; 2015a.
- C. ASTM G153 - Standard Practice for Operating Enclosed Carbon Arc Light Apparatus for Exposure of Nonmetallic Materials; 2013.

**1.04 SUBMITTALS**

- A. See Section 01 30 00 - Administrative Requirements, for submittal procedures.
- B. Product Data: Provide data indicating coating materials.
- C. Manufacturer's Certificate: Certify that products meet or exceed specified requirements.
- D. Manufacturer's Installation Instructions: Indicate special procedures and perimeter conditions requiring special attention.
- E. Maintenance Data: Include cleaning procedures and repair and patching techniques.

**1.05 QUALITY ASSURANCE**

- A. Manufacturer Qualifications: Company specializing in manufacturing the Products specified in this section with minimum three years documented experience.
- B. Applicator Qualifications: Company specializing in performing the work of this section with minimum Five years documented experience.

**1.06 FIELD CONDITIONS**

- A. Do not install materials when temperature is below 55 degrees F or above 90 degrees F.
- B. Maintain this temperature range, 24 hours before, during, and 72 hours after installation of coating.
- C. Restrict traffic from area where coating is being applied or is curing.

**1.07 WARRANTY**

- A. Warranty: Include coverage for bond to substrate.

**PART 2 PRODUCTS**

**2.01 MANUFACTURERS**

- A. Concrete and Masonry Coatings:
  - 1. Textured Coatings of America, Inc.: [www.texcote.com](http://www.texcote.com).
  - 2. Substitutions: Section 01 60 00 - Product Requirements.

**2.02 CONCRETE AND MASONRY COATINGS**

- A. Provide high-build, weather resistant coating systems that meet the following minimum performance criteria, unless more stringent criteria are specified:
  - 1. Salt Spray Resistance: Passes when tested according to ASTM B117 for 2000 hours.

2. Surface Burning Characteristics: Flame spread/Smoke developed index of 0/0, maximum, when tested in accordance with ASTM E84.
3. Accelerated Outdoor Exposure: Passes when tested according to ASTM G153 for 5,000 hours.

### **2.03 MATERIALS**

- A. Coatings - General: Provide complete systems formulated and recommended by manufacturer for the applications indicated, in the thicknesses indicated.
  1. Maximum volatile organic compound (VOC) content: As required by applicable regulations.

**END OF SECTION**

**SECTION 26 23 00**

**LOW VOLTAGE SWITCHBOARDS**

**PART 1 - GENERAL**

**1.1 SECTION INCLUDES**

- A. Main Switchboard - Furnish and install the Service Entrance switchboard(s) as herein specified and shown on the associated electrical drawings in a main-tie-main configuration.

**1.2 REFERENCES**

The switchboard(s) and overcurrent protection devices referenced herein are designed and manufactured according to the following appropriate specifications.

- A. ANSI/NFPA 70 - National Electrical Code (NEC).
- B. ANSI/IEEE C12.16 - Solid-State Electricity Metering.
- C. ANSI C57.13 - Instrument Transformers.
- D. NEMA AB 1 - Molded Case Circuit Breakers and Molded Case Switches.
- E. NEMA PB 2 - Deadfront Distribution Switchboards, File E8681
- F. NEMA PB 2.1 - Proper Handling, Installation, Operation and Maintenance of Deadfront Switchboards Rated 600 Volts or Less.
- G. NEMA PB 2.2 - Application Guide for Ground Fault Protective Devices for Equipment.
- H. UL 50 - Cabinets and Boxes.
- I. UL 98 - Enclosed and Dead Front Switches.
- J. UL 489 - Molded Case Circuit Breakers.
- K. UL 891 - Dead-Front Switchboards.
- L. UL 943 - Standard for Ground Fault Circuit Interrupters.
- M. Federal Specification W-C-375B/Gen - Circuit Breakers, Molded Case, Branch Circuit and Service.

**1.3 SUBMITTALS**

- A. Shop Drawings shall indicate front and side enclosure elevations with overall dimensions shown; conduit entrance locations and requirements; nameplate legends; one-line diagrams; equipment schedule; and switchboard instrument details.

**1.4 QUALIFICATIONS**

- A. To be considered for approval, a manufacturer shall have specialized in the manufacturing and assembly of switchboards for at least fifty (50) years.

- B. Furnish products listed by Underwriters Laboratories Incorporated and in accordance with standards listed in Article 1.03 - References.
- C. The manufacturing facility shall be registered by Underwriters Laboratories Inc. to the International Organization for Standardization ISO 9002 Series Standards for quality.

#### **1.5 DELIVERY, STORAGE, AND HANDLING**

- A. Deliver, store, protect, and handle products in conformance with manufacturer's recommended practices as outlined in applicable Installation and Maintenance Manuals.
- B. Each switchboard section shall be delivered in individual shipping splits for ease of handling. They shall be individually wrapped for protection and mounted on shipping skids.
- C. Inspect and report concealed damage to carrier within their required time period.
- D. Store in a clean, dry space. Maintain factory protection and/or provide an additional heavy canvas or heavy plastic cover to protect structure from dirt, water, construction debris, and traffic. Where applicable, provide adequate heating within enclosures to prevent condensation.
- E. Handle in accordance with NEMA PB 2.1 and manufacturer's written instructions. Lift only by lifting means provided for this express purpose. Handle carefully to avoid damage to switchboard internal components, enclosure, and finish.

#### **1.6 ENVIRONMENTAL REQUIREMENTS**

- A. Conform to NEMA PB 2 service conditions during and after installation of switchboards.

#### **1.7 MAINTENANCE MATERIALS**

- A. Provide one (1) set of installation and maintenance instructions with each switchboard. Instructions are to be easily identified and affixed within the incoming or main section of the line-up.

#### **1.8 WARRANTY**

- A. Manufacturer shall warrant equipment to be free from defects in materials and workmanship for the lesser of one (1) year from date of installation or eighteen (18) months from date of purchase.

### **PART 2 - PRODUCTS**

#### **2.1 MANUFACTURERS**

- A. Shall be Square D Company, General Electric or EATON.
- B. Substitutions must be submitted in writing three (3) weeks prior to original bid date with supporting documentation demonstrating that the alternate manufacturer conforms to all aspects of the specifications herein.
- C. The manufacture of the switchboard shall be the same as the manufacturer of the circuit breakers or the switches mounted in the switchboard.

- D. All new panelboards and switchboards on this project shall be by the same manufacture as the switchboard for the purposes of stocking common breaker types, series ratings, etc.

## 2.2 SWITCHBOARD – GENERAL

- A. Short Circuit Current Rating: Switchboards shall be rated with a minimum short circuit current rating of 65,000 RMS symmetrical amperes at 480 VAC maximum.
- B. Future Provisions: All unused spaces provided, unless otherwise specified, shall be fully equipped for future devices, including all appropriate connectors and mounting hardware.
- C. Enclosure:
  - 1. Sections shall be aligned front and rear.
  - 2. Removable steel base channels (1.5 inch floor sills) shall be bolted to the frame to rigidly support the entire shipping section for moving on rollers and floor mounting.
  - 3. The switchboard enclosure shall be painted on all exterior surfaces. The paint finish shall be a medium gray, ANSI #49, applied by the electro-deposition process over an iron phosphate pre-treatment.
  - 4. All front covers shall be screw removable with a single tool and all doors shall be hinged with removable hinge pins.
  - 5. Top and bottom conduit areas shall be clearly indicated on shop drawings.
- D. Nameplates: Provide 1 inch high x 3 inches engraved laminated (Gravoply) nameplates for each device. Furnish black letters on a white background for all voltages.
- E. Bus Composition: Shall be plated copper. Plating shall be applied continuously to all bus work. The switchboard bussing shall be of sufficient cross-sectional area to meet UL Standard 891 temperature rise requirements. The phase [and neutral] through-bus shall have an ampacity as shown in the plans. For 4-wire systems, the neutral shall be of equivalent ampacity as the phase bus bar. Tapered bus is not acceptable. Full provisions for the addition of future sections shall be provided. Bussing shall include all necessary hardware to accommodate splicing for future additions.
- F. Bus Connections: Shall be bolted with Grade 5 bolts and conical spring washers.
- G. Ground Bus: Sized per NFPA70 and UL 891 Tables 25.1 and 25.2 and shall extend the entire length of the switchboard. Provisions for the addition of future sections shall be provided.

## 2.2 A SWITCHBOARD - INCOMING MAIN SECTION DEVICES

- A. Two-step stored energy electronic trip molded case circuit breaker(s)
  - 1. Circuit protective devices shall be two-step stored energy type circuit breaker(s).
  - 2. Circuit breaker trip system shall be a microprocessor-based true rms sensing design with sensing accuracy through the thirteenth (13th) harmonic.

3. The integral trip system shall be independent of any external power source and shall contain no less than industrial grade electronic components.
4. Circuit breakers shall be equipped with back-up thermal and magnetic trip system.
5. The ampere rating of the circuit breaker shall be determined by the combination of an interchangeable rating plug, the sensor size and the long-time pickup adjustment on the circuit breaker. The sensor size, rating plug and switch adjustments shall be clearly marked on the face of the circuit breaker. Circuit breakers shall be UL Listed to carry 100% of their ampere rating continuously when applied in QED switchboards.
6. The following time/current response adjustments shall be provided. Each adjustment shall have discrete settings and shall be independent from all other adjustments.

Long Time Pickup & Long Time Delay

Short Time Pickup & Short Time Delay ( $I^2t$  IN &  $I^2t$  OUT)

Instantaneous Pickup

Ground Fault Pickup & Ground Fault Delay ( $I^2t$  IN and  $I^2t$  OUT)

7. A means to seal the rating plug and trip unit adjustments in accordance with NEC Section 240-6(b) shall be provided.
8. Local visual trip indication for overload, short circuit and ground fault trip occurrences shall be provided.
9. An ammeter to individually display all phase currents flowing through the circuit breaker shall be provided. Indication of inherent ground fault current flowing in the system shall be provided on circuit breakers with integral ground fault protection]. All current values shall be displayed in True rms with 2% accuracy.
10. Long Time Pickup indication to signal when loading approaches or exceeds the adjusted ampere rating of the circuit breaker shall be provided.
11. The trip system shall include a Long Time memory circuit to protect against intermittent overcurrent conditions above the long time pickup point. Means shall be provided to reset Long Time memory circuit during primary injection testing.
12. Circuit breaker trip system shall be equipped with an externally accessible test port for use with a Universal Test Set. Provide one (1) Universal Equipment Test Set for this project job for final inspection. This test set shall be suitable for testing all electric circuit breakers specified for this project. No disassembly of the circuit breaker is required for testing.

~~13. Communications capabilities for remote monitoring of circuit breakers trip system, to include phase and ground fault currents, pre-trip alarm indication, switch settings and trip history information shall be provided.~~

~~14. Circuit breakers shall be provided with Zone Selective Interlocking (ZSI) communications capabilities on the short time and ground fault functions~~



~~compatible with all other electronic trip circuit breakers and external ground fault sensing systems.~~

- ~~15.13.~~ True two-step stored energy mechanism with five (5) cycle closing time shall be provided. All circuit breakers shall have multiple CHARGE/CLOSE provisions allowing the following sequence:

CHARGE, CLOSE, RECHARGE, OPEN/CLOSE/OPEN

- ~~16.14.~~ Local control pushbuttons to OPEN and CLOSE circuit breaker shall be provided. Color coded visual indication of contact position (OPEN or CLOSED) shall be provided on the face of the circuit breaker. Local manual charging following CLOSE operation shall be provided. Color coded visual indication of mechanism CHARGED and DISCHARGED position shall be provided on the face of the circuit breaker. Visual indicator shall indicate CHARGED only when closing springs are completely charged.

- ~~17.15.~~ Each circuit breaker shall be electrically operated to permit remote CHARGE, CLOSE, and OPEN capabilities. Electrically operated circuit breaker shall be equipped with charge contact switch for remote indication of mechanism charge status.

- ~~18.16.~~ Provide the following interlocking capabilities:

- a. cell door interlock
- b. key interlock for main-tie-main
- c. lock off

- ~~19.17.~~ Equipment Ground Fault Protection

- a. Circuit breaker(s) shall be provided with integral equipment protection for grounded systems.
- b. The ground fault system shall be of the residual type.

- ~~20.18.~~ Terminations

- a. All lugs shall be UL Listed to accept solid and/or stranded copper conductors. Lugs shall be suitable for 75° C rated wire, sized according to the 75° C temperature rating in the NEC.
- b. All circuit breakers shall be UL Listed to accept field installable/removable compression type lugs.

- B. Individually fixed mounted through 5000 A  
1. Mains and Tie circuit breaker shall be individually fixed mounted.

## 2.2 B SWITCHBOARD - DISTRIBUTION SECTION DEVICES

- A. Group mounted circuit breakers through 1200A.

1. Circuit breaker(s) shall be group mounted plug-on with mechanical restraint on a common pan or rail assembly.

2. The interior shall have three flat bus bars stacked and aligned vertically with glass reinforced polyester insulators laminated between phases. The molded polyester insulators shall support and provide phase isolation to the entire length of bus.
3. Circuit breaker(s) equipped with line terminal jaws shall not require additional external mounting hardware. Circuit breaker(s) shall be held in mounted position by a self-contained bracket secured to the mounting pan by fasteners. Circuit breaker(s) of different frame sizes shall be capable of being mounted across from each other.
4. Line-side circuit breaker connections are to be jaw type.
5. All unused spaces provided, unless otherwise specified, shall be fully equipped for future devices, including all appropriate connectors and mounting hardware.
6. Electronic trip molded case full function 100% rated circuit breakers.
  - a. All electronic circuit breakers shall have the following time/current response adjustments: Long Time Pickup, Long Time Delay, Short Time Pickup, Short Time Delay, Ground Fault Pickup, Ground Fault Delay and Instantaneous settings. Each adjustment shall have discrete settings (fully adjustable) and shall be independent of all other adjustments.
  - b. Circuit breaker trip system shall be a microprocessor-based true rms sensing designed with sensing accuracy through the thirteenth (13<sup>th</sup>) harmonic. Sensor ampere ratings shall be as indicated on the associated [schedule] [drawing].
  - c. Local visual trip indication for overload, short circuit and ground fault trip occurrences.
  - d. Long Time Pickup indication to signal when loading approaches or exceeds the adjustable ampere rating of the circuit breaker shall be provided.
  - e. Communications capabilities for remote monitoring of circuit breaker trip system, to include phase and ground fault currents, pre-trip alarm indication, switch settings, and trip history information shall be provided.
  - f. Circuit breaker shall be provided with Zone selective Interlocking (ZSI) communications capabilities on the short-time and ground fault functions compatible with all other electronic trip circuit breakers and external ground fault sensing systems as noted on [schedules] [drawings]
  - g. Furnish thermal magnetic molded case circuit breakers for 250A frames and below.

### **2.3 METERING (CUSTOMER)**

#### **A. Manufacturers:**

1. Square D Model PM 8000 series or equivalent by GE or EATON>.
2. Ethernet Modbus TCP/IP Communication

3. Substitutions: substitutions shall be made only after proper verification

## 2.4 METERING TRANSFORMERS

- A. Manufacturer: Shall be Square D Company.
- B. Current Transformers: ANSI C57.13; 5 ampere secondary.
- C. Voltage Transformers: ANSI C57.13; 120 V single secondary, (Not required for type PM meters)

## 2.5 ACCESSORIES

- A. For switchboards installed outdoor only, provide thermostatically-controlled electric heaters in each section. Provide terminals for separate source connection of heater power circuit. Voltage Rating: 120 V. Provide control power transformer with the total VA rating of the electric heaters in the switchboard.
- ~~B. Provide a Masterpack NW Remote Racking Device with mounting bracket kit for NW remote racking for all breakers. Provide mounting brackets modification/installation and all required accessories for a complete breaker racking system.~~

## 2.6 RELATED SECTION

- A. Section 26 43 13- TRANSIENT VOLTAGE SURGE SUPPRESSION DEVICES IN SWITCHBOARDS

## 2.7 MAIN PROTECTIVE DEVICES

- A. The main breakers and the tie breaker are to 100 percent rated 3-pole insulated case with two step stored energy mechanism. Breakers shall be able to be electrically operated from a remote mounted control station. In addition to the electrical operators installed on the front of the switchboard, the remote mounted station shall consist of open/closed momentary contact pushbuttons mounted in lockable NEMA 1 wall enclosure.
- B. Mount remote operators on wall-mounted enclosure inside the electrical room and provide a label on the front of the enclosure with the inscription. "MAIN SWITCHBOARDS REMOTE OPERATOR"

## 2.8 INTEGRATED ROTATABLE INFRARED (IR) VIEWING PORT

Provide ~~fixed integrated rotatable~~ IR windows to view incoming terminations and bus splices per the plant's recommendations. ~~viewing port that provides single point viewing point that enables the thermal scanning of all live connections without requiring opening of the main bus enclosure or exposure of live parts.~~

The port shall be easily usable by a wide variety and modules of commercially available thermal scanning devices, without requiring any proprietary connectors, adapters or other components.

For the installation of one or more fixed IR windows to be considered an acceptable alternative on this project, the manufacturer shall provide detailed drawings prepared by a qualified engineer detailing how all live terminals will be viewable. The manufacturer shall commit that should all terminals not be viewable once installed, the manufacturer shall rectify the situation at his own expense.

Infrared ports/windows must be factory installed with full manufacturer warranty. Aftermarket or contractor installed kits are not acceptable.

## **2.9 LISTING**

The switchgear shall be UL listed as suitable for use as service entrance equipment.

## **2.8 FACTORY TESTING**

The switchgear shall be completely assembled, wired, adjusted and tested at the factory. After assembly, the completed switchgear shall be tested to assure the accuracy of the wiring and the functioning of all equipment. The main bus system shall be given a dielectric test of 2200 volts for one minute between live parts and ground between opposite polarities. The manufacturer shall notify the Owner's Representative two weeks prior to the date the tests are to be performed

## **PART 3 - EXECUTION**

### **3.1 INSPECTION**

- A. Examine area to receive switchboard to provide adequate clearance for switchboard installation.
- B. Check that concrete pads are level and free of irregularities.
- C. Start work only after unsatisfactory conditions are corrected.

### **3.2 INSTALLATION**

- A. Install switchboard in accordance with manufacturer's written guidelines, the NEC, and local codes.

### **3.3 FIELD QUALITY CONTROL**

- A. Inspect completed installation for physical damage, proper alignment, anchorage, and grounding.
- B. Measure, using a Megger, the insulation resistance of each bus section phase-to-phase and phase-to-ground for one minute each, at minimum test voltage of 1000 VDC; minimum acceptable value for insulation resistance is 1 megohms. NOTE: Refer to manufacturer's literature for specific testing procedures.
- C. Check tightness of accessible bolted bus joints using calibrated torque wrench per manufacturer's recommended torque values.
- D. Physically test key interlock systems to check for proper functionality.
- E. Test ground fault systems by operating push-to-test button.

### **3.4 ADJUSTING**

- A. Adjust all operating mechanisms for free mechanical movement per manufacturers specifications.
- B. Tighten bolted bus connections in accordance with manufacturer's instructions.

- C. Adjust circuit breaker trip and time delay settings to values as indicated on the coordination study.

### **3.5 TESTING**

- A. After installation and before acceptance by Owner, this Contractor shall provide the services of an independent organization (independent from the Contractor) to performance test of all ground trips in accordance with NEC 230.95©. this test shall involve passing a primary current through the current sensor with a suitable, low voltage test set and timer, which shall allow verification that the trip units track their published curves and that they actually trip the devices on which they are applied. This shall include the polarity of the current sensors and give an indication of satisfactory operation of all instruments.
- B. The contractor shall notify the Owner's Representative of this test five days in advance so the test can be properly witnessed.

### **3.6 CLEANING**

- A. up scratched or marred surfaces to match original finish.

**END OF SECTION**